



monarchlathe.com

LODGE & SHIPLEY



POWER... PRECISION... PERFORMANCE!

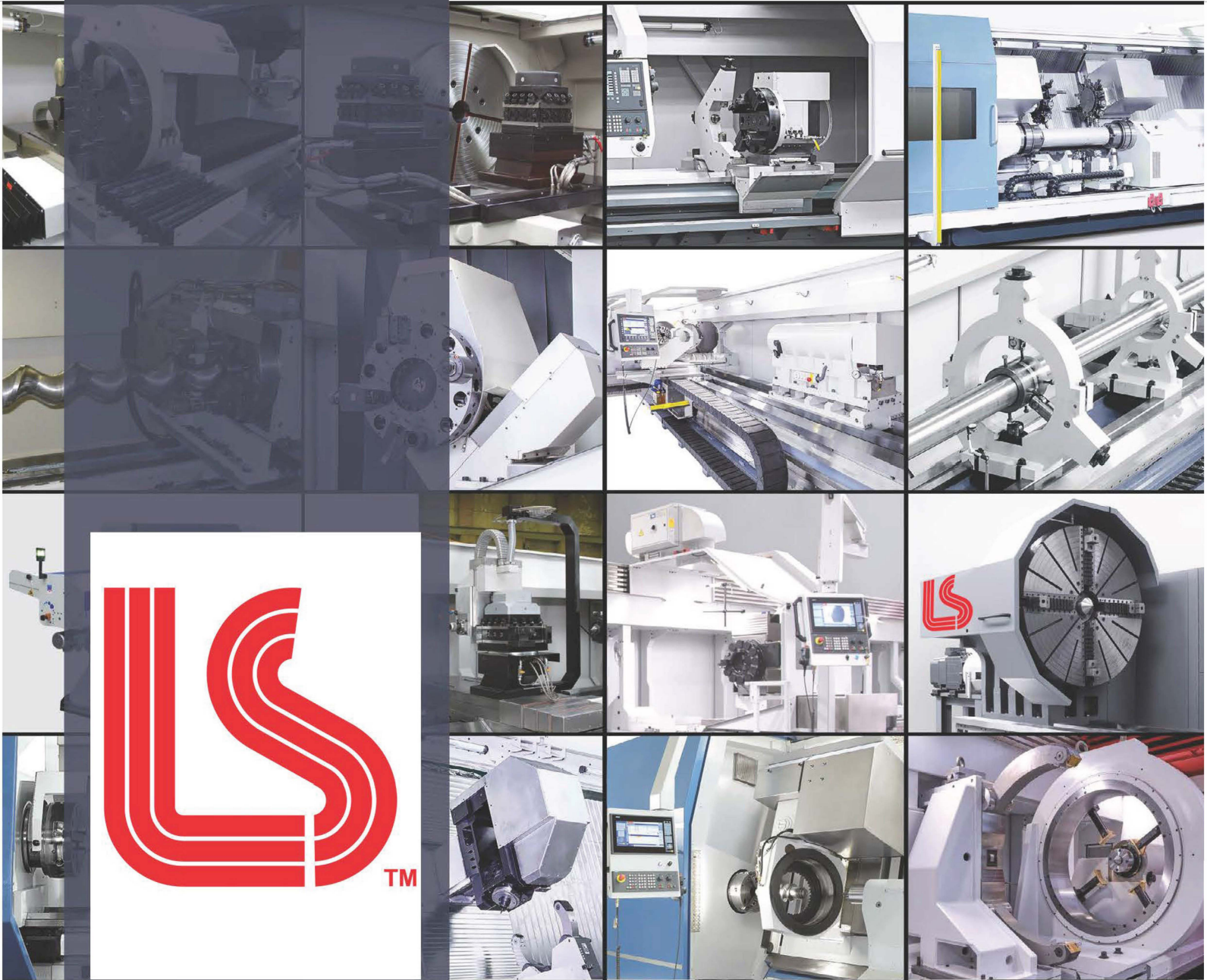

for impressive performances

**FORM MORE INFORMATION CONTACT:
MONARCHLATHES, L.P.**

**615 OAK AVENUE
P.O. BOX 4609
SIDNEY, OHIO
45365-4609**

**PHONE: 937-492-4111 EMAIL: sales@monarchlathe.com
WEBSITE: www.monarchlathe.com**



LODGE & SHIPLEY POWERTURN 630/710

LODGE & SHIPLEY lathes main features include exceptional structural stability and precision machining. With many years of experience in the production of machine tools, innovative solutions and attention to detail. The POWERTURN is true example of this with its durability and high precision. During assembly we guarantee high quality machines with high precision. Thanks to the perfect combination of high performance and affordability, our products are the most advantageous economic solution for your company.

The POWERTURN 630/710 lathes are precise and of the highest quality that are made in Poland and all components used in our machines come from our reputable suppliers. Standard equipment makes the POWERTURN lathes an advanced machine that increases efficiency in production from the very first day of use.

The standard equipment is extensive and makes the POWERTURN lathe an advanced work tool that increases the efficiency of your production from the very first day of use. The very large number of additional options that can be used allows special requirements to be met.

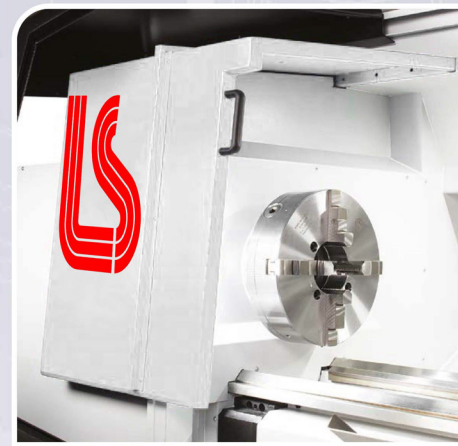

Chuck cover



The special 3-V design of the bed with deeply hardened and ground guides ensures stiffness and stability. All bed lengths are made as one mono-block casting.

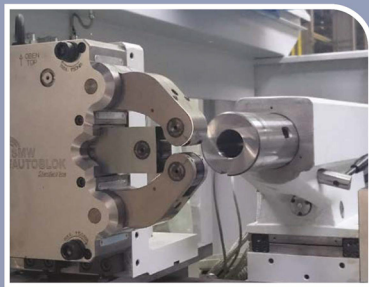
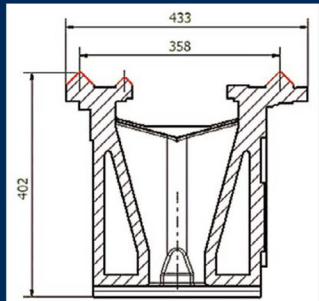

Wide range of self centering hydraulic steady restss



Follow rest



Surprisingly easy machine programming. POWERTURN lathes with a Siemens Sinumerik One controller allow you to work in manual, semi-automatic and full CNC modes. Operator-friendly control system ensures comfortable and effective work.

Main control features:

- easy programming with graphical representation that does not require knowledge of DIN/ISO
- very short programming time
- clear overview of all steps machining process
- simple tool management
- large selection of ready cycles machining and measuring



Steady rests



Fanuc or Fagor controller as an option



Pneumatic chuck



Headstock with full contouring C axis and actuating cylinder for hydraulic chuck



Hydraulic chuck in cooperation with robot

LODGE & SHIPLEY POWERTURN 630/710 P

The POWERTURN 630/710 P has been designed for processing pipes due the large spindle bore the process is exceptionally simple. The standard bore available is $\varnothing 165$ mm and an optional spindle bore of $\varnothing 190$ mm, giving manufactures more options.



Direct spindle drive with automatic, programmable planetary gearbox.



Second spindle nose with complete interlocked covers



TUR MN 630 P equipped with bar feeder

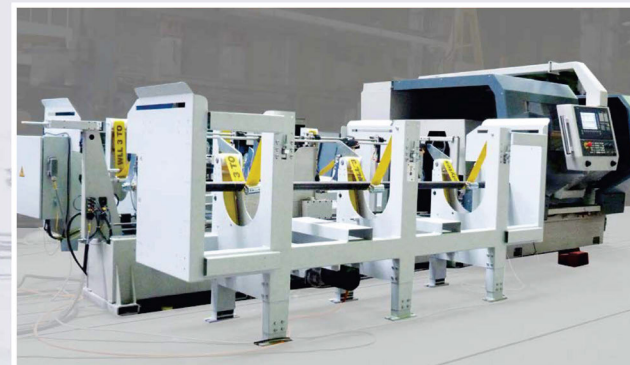

Special feeder for rotating bar

VARIOUS TOOLING SYSTEMS:



Combination of 2 horizontal head turrets

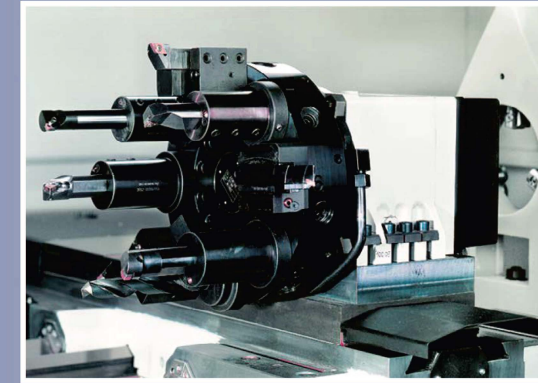

Disc turret or static tools

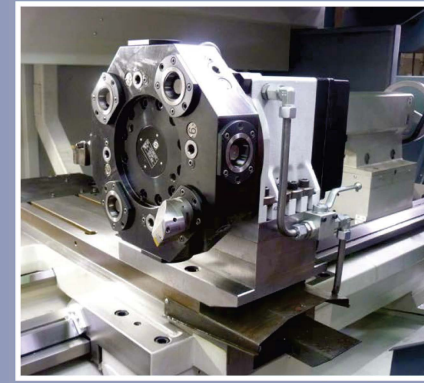

Tool turret with Capto seats



Manual upper cross-slide with Multifix C



Installation of whirling unit



Boring bar attachment mounted on cross-slide T slots

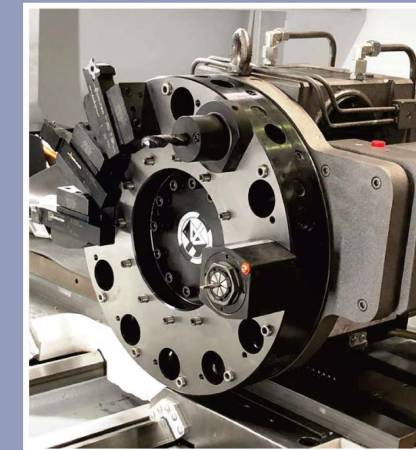

Turret for driven tools with options for C-axis spindle positioning:

- driven by main motor in combination with hydraulic brake and spindle encoder
- full contouring C-axis driven directly by separate servo motor



WTO tooling system for turning, drilling and milling operation

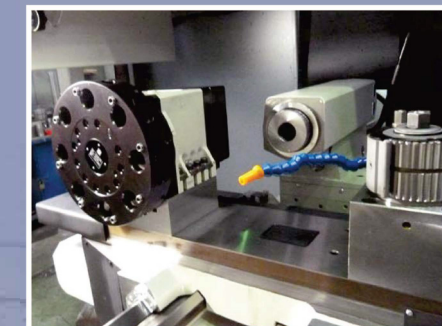

Multifix-turret combination



Parat turret optionally with Capto seats

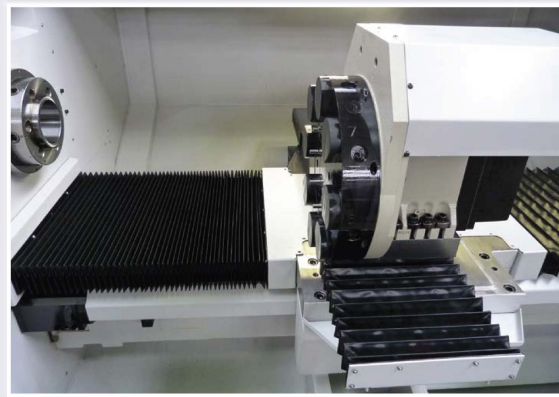

Z and X axis guideways bellows covers



Chip pan at the front of the machine



Additional cover of tailstock area

Special machine with tool turret, milling unit automatic workpiece positioning and clamping system.

STANDARD EQUIPMENT:

- Siemens Sinumerik One
- Tool post MULTIFIX C (without tool holders)
- Coolant system
- Hydraulic aggregate (option for machines in P version)
- Rotary operator panel on sliding arm
- Easy connection of the tailstock and support thanks to the "come-along" system
- Absolute encoders of X and Z axis motors
- Fixed rear wall
- Front doors with interlock
- Handwheels for manual operation with "click" position
- Automatic programmable gearbox
- USB port
- One-year Siemens service contract
- Central lubrication system



Additional control panel with hand-wheels installed on support



Third Hand wheel (MPG mini handheld unit) Siemens

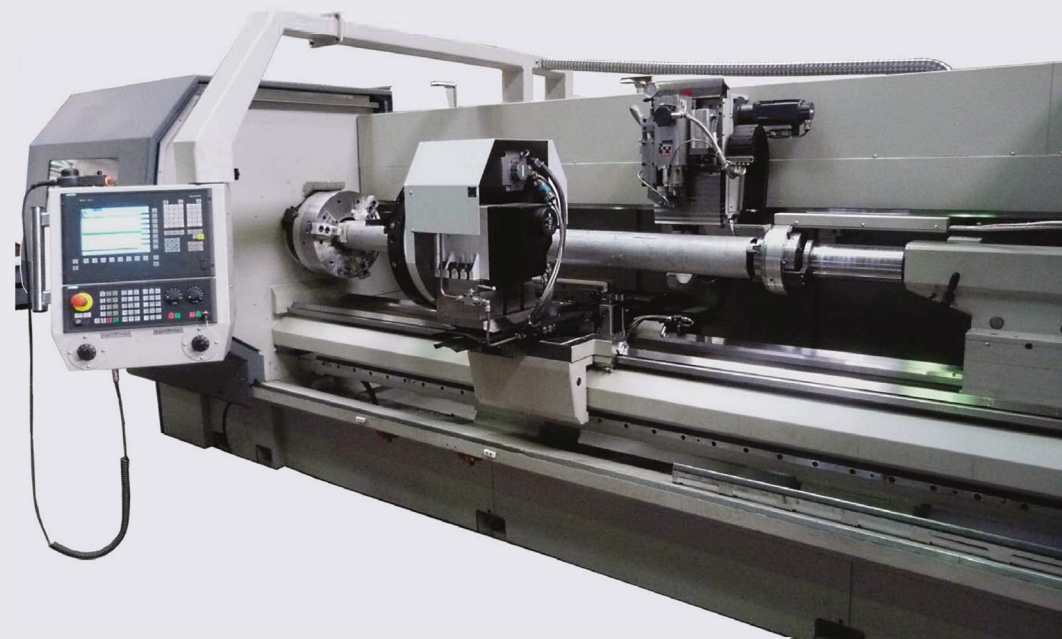

TECHNICAL PRAMETERS: POWERTURN 630/630P/710/710P*

POWERTURN		630	630 P	710	710 P
CAPACITY					
Distance between centers	mm	1.000 - 2.000-3.000-4.000-5.000 -6.000			
Swing over bed	mm	630		710	
Swing over saddle	mm	370		450	
Max. weight of workpiece between chuck and tailstock (without steadies).	kg	2.000		2.000	
Max. Weight of workpiece in chuck only	kg	600		600	
HEADSTOCK					
Number of spindle ranges		2		2	
Spindle speed ranges	rpm	I: 2-560, II: 200-2.500	I: 2-430, II: 200-1.850	I: 2-560, II: 200-2.500	I: 2-430, II: 200-1.850
Spindle nose		D 1-11 DIN 55029	2xA2-11/15 DIN 55026	D 1-11 DIN 55029	2xA2-11/15 DIN 55026
Internal taper of the spindle	mm	150		1:20	
Spindle bore	mm	140		165 / 190	
Main drive motor power	kW	22,5 (S1)		23 (S6)	
Max. Turning torque	Nm	2.200		2.050	
SUPPORT					
Cross slide travel X-axis	mm	390		410	
Rapid travel Z-axis	m/min	8			
Rapid travel X-axis	m/min	8			
Feed force transverse	kN	10			
Feed force longitudinal	kN	15			
Ball screw Z-axis (1-3m b.b.c.)	mm	40			
Bal screw Z-axis (4m b.c.)	mm	63			
Ball screw X-axis	mm	32			
QC Toolpost Type Multifix	Size	C			
TAILSTOCK					
Quill diameter	mm	100			
Quill taper	MT	5			
Quill stroke	mm	200			
GENERAL					
Width of bed	mm	433			
Width of machine	mm	2.500			
Height of machine	mm	2.100			
WEIGHT OF MACHINE					
1.000mm	kg	5.100		5.300	
2.000mm	kg	5.900		6.100	
3.000mm	kg	6.700		6.900	
4.000mm	kg	7.500		7.700	
5.000mm	kg	8.300		8.500	
6.000mm	kg	9.100		9.300	

* The data in the table refer to the basic version of the lathe. They may differ depending on the version of the machine and additional equipment. In particular, the tool system, special covers and doors, type of tailstock, handle, steady rests and other options.

PROFITTURN 800/950/1100

PROFITTURN 800/950/1100 is designed for heavy machining of up to 1,100 mm in diameter and offering manufacturers exceptional stability and high precision with a monolithic bed. LODGE & SHIPLEY have many years of experience in the production of machine tools and innovative design. Every stage of the production process is carefully taken to guarantee reliability in the products available.



Easy access to the working area. Surprisingly small distance to spindle axis.



The standard tailstock has 125 mm (4.9") quill diameter. For heavy duty machining the diameter can be increased up to 140 mm (5.5") or 160 mm (6.3") The quill is located in a specially extended body. Optionally the tailstock can be equipped with hydraulic quill, bearing system for the dead center, independent NC drive and hydraulic clamping system to the bed.

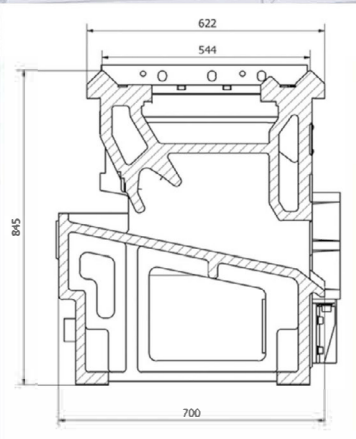

Special, mono-block type bed made of cast iron is a rigid structure which perfectly absorbs vibrations. Extra wide, deeply hardened and ground guide ways 3-V ensure precise machining and excellent surface quality. All of the above guarantee long-life accurate operation of the lathe.

The headstock is made of one mono-block casting. Hand scraped contact surfaces ensure the best fit and durable alignment. High precision spindle bearings guarantee excellent stability and accuracy of machining.

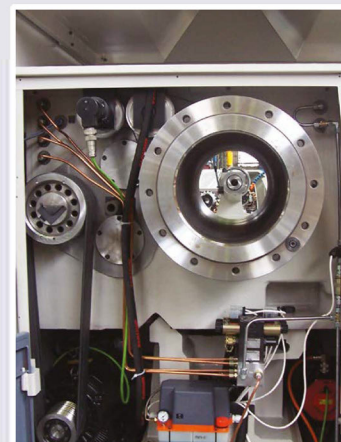

OPTIONAL EQUIPMENT:



◀ Machining of rotor shaft

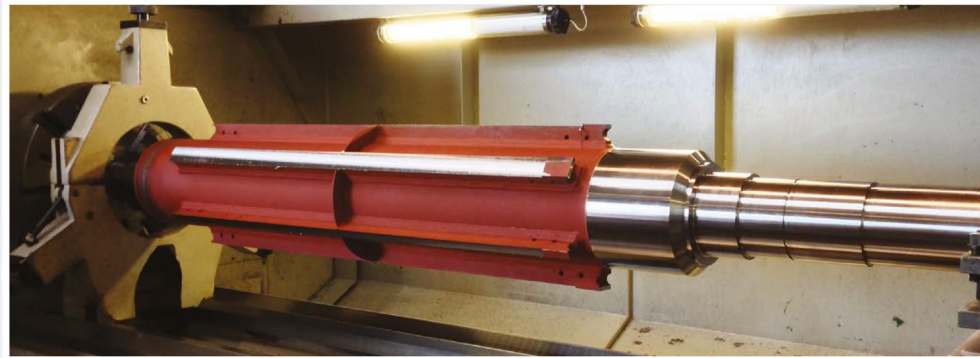

▲ Additional chip conveyor at the front of the machine

◀ CNC machine with steady rests system for long shafts and pipes

▼ Full enclosure

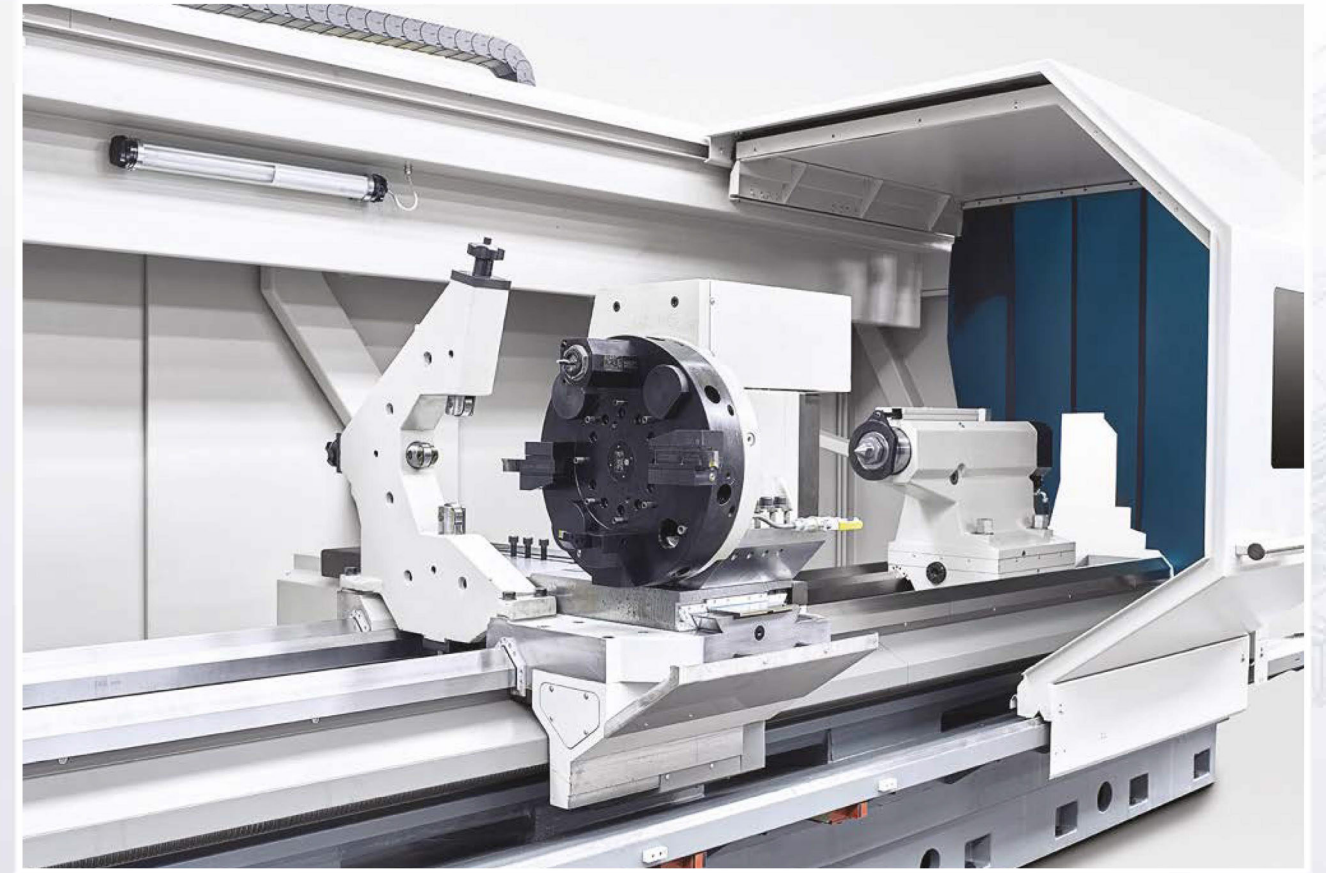

A wide range of rests is available to suit different machining applications: manual, hydraulic self-centring, steady or follow rests, C-form, ring rests and other.

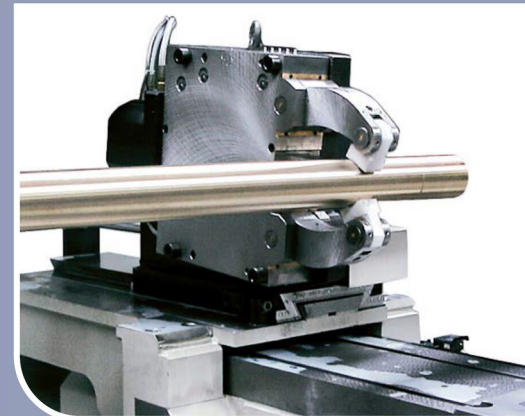
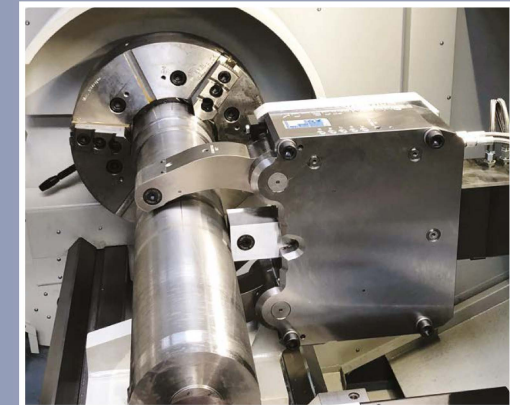
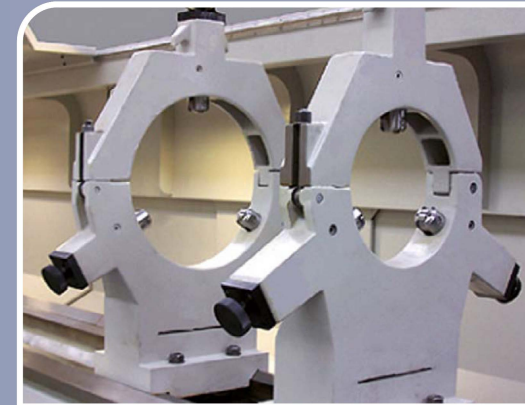

OPTIONAL EQUIPMENT:

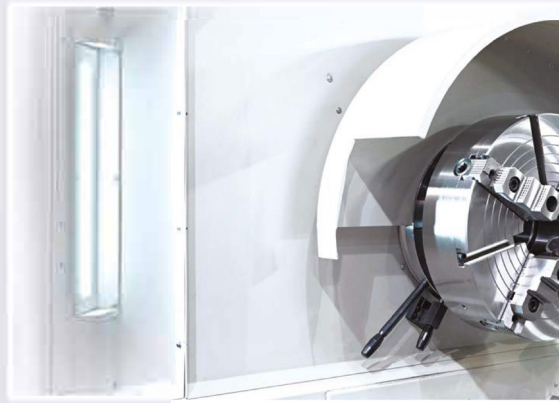

LED light front



Mist collector

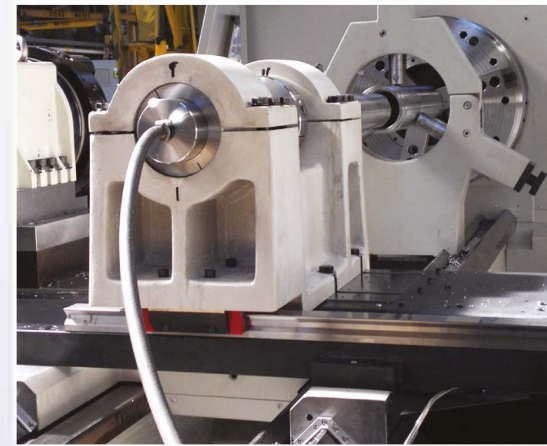

Heavy-duty boring bar attachment mounted on rear T-slots

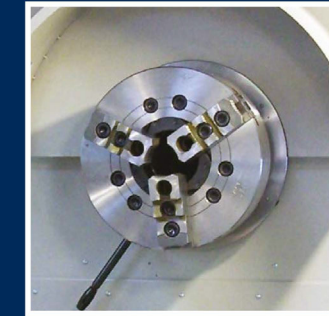

A wide range of manual, hydraulic and pneumatic chucks

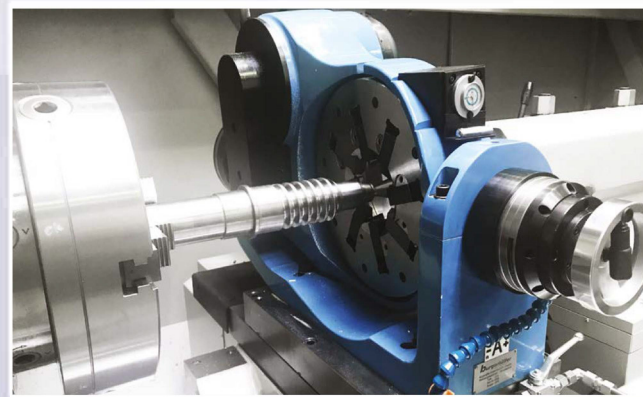

Whirling head

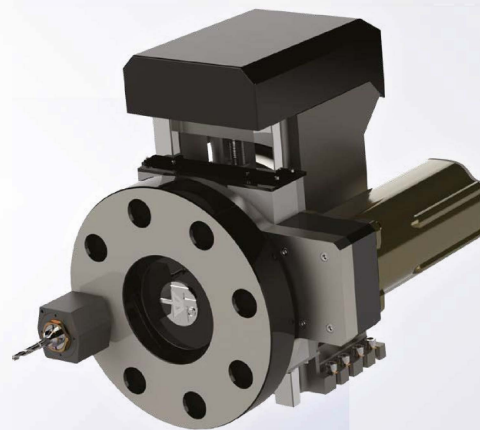

YAX-C-DEFINITIVA, Barruffaldi turret with Y axis



BMT driven tool head with integrated Y axis.

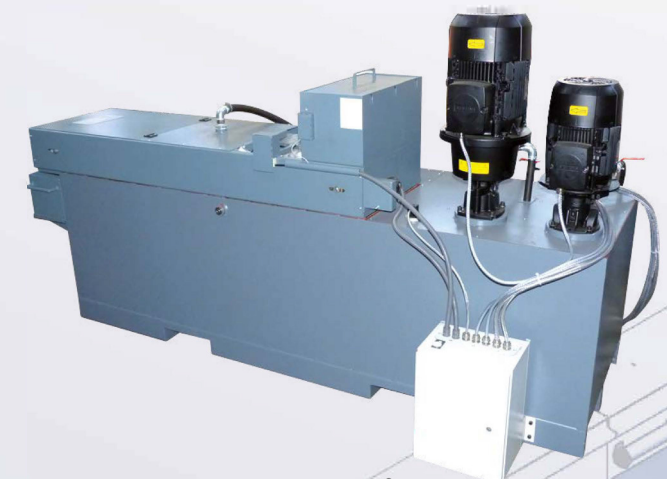

Additional coolant tank with filtration and high pressure pump

Tooling system:



Parat toolpost with optional Capto seat

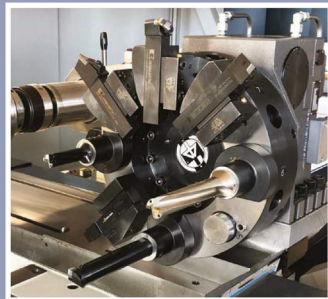

Disc turret for static tools



Combination of two 4-positions head-type turrets



Head-turret with milling unit on the rear T-slots



Turret for driven tools with C axis



Standard Multifix D1 toolpost

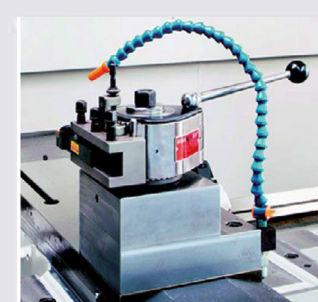

Milling-drilling units:

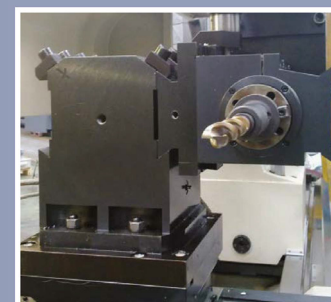

Tooling system mounted on cross-slide T slots



Unit mounted on tool turret



WTO system (VDIS0) enables drilling and milling operations with a high torque. Normal turning is still possible. Available version with Y-axis.

Spindle equipment:

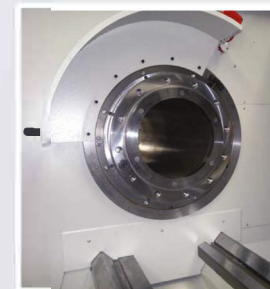

Available spindle bores: (11140mm (standard), 0220mm, 0320mm, 11360mm, 11450mm)



Second spindle nose

OŚ C:

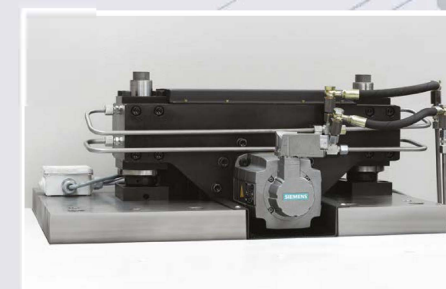

Full contouring C axis with independent, direct drive on the spindle enables precise milling operations with interpolating workpiece

STANDARD EQUIPMENT:

- Siemens Sinumerik One
- Tool post MULTIFIX D1 (without tool holders)
- Coolant system
- Hydraulic aggregate
- Rotary operator panel on a sliding arm
- Easy connection of the tailstock and support thanks to the „come-along” system
- Absolute encoders of X and Z axis motors
- Sliding rear covers
- Front doors with interlock
- Handwheels with „click” positions
- Automatic programmable gearbox
- USB port
- One-year Siemens service contract
- Central lubrication system

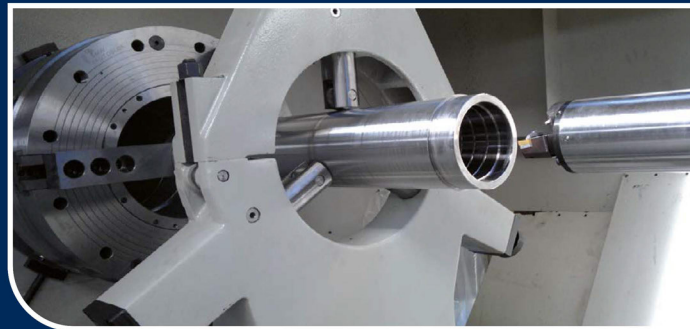

Tailstock with independent drive by push button



Tailstock on additional X-axis

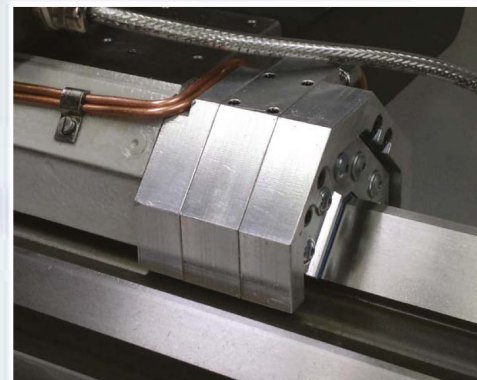

Scrapers with compressed air for guideways

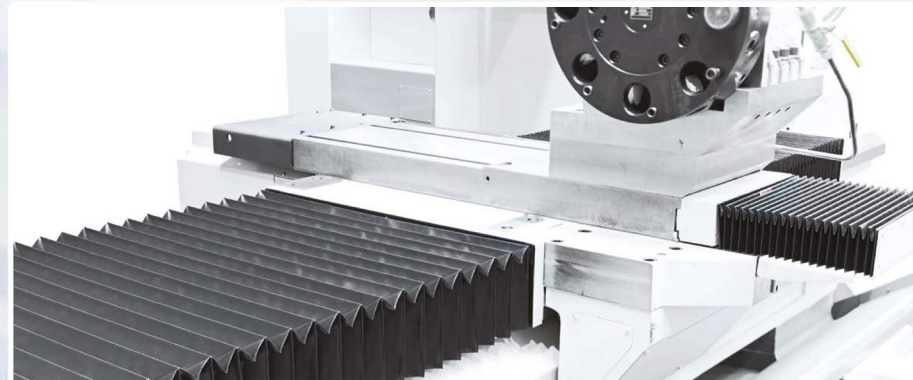

Bellows covers

Tailstock executions:

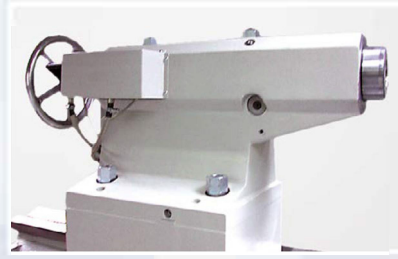

Quill operated both manually and hydraulically

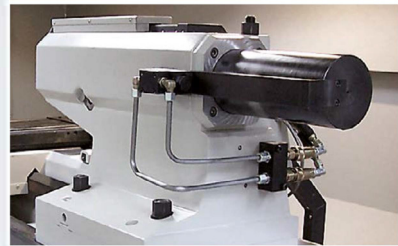

Hydraulic tailstock quill

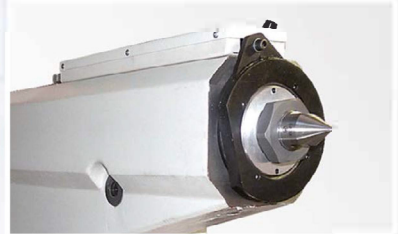

Heavy-duty tailstock with 160 mm (6.3”) quill diameter for increased rigidity and load capacity

TECHNICAL PARAMETERS: PROFITURN 800/950/1100				
PROFITURN		800	950	1100
CAPACITY				
Distance between centres	mm	2.000 - 3.000 - 4.000 - 5.000 - 6.000 - 8.000 ... - 16.000		
Swing over bed	mm	800	950	1.100 (OPTIONAL 1.200)
Swing over saddle	mm	500	630	790 (OPTIONAL 830)
Max. weight between chuck and tailstock (without steadies)	kg	4.000 (OPTIONAL 7.000)		
Max. weight in chuck only	kg	1.000		
HEADSTOCK				
Number of spindle ranges		2		
Top spindle speed ranges (standard machine with 140 mm spindle bore)	rpm	I: 4-360, 11: 200-1800	I: 4-300, II: 160-1200	
Main drive motor power 100%	kW	25		
Max. Turning torque	Nm	4.100	4.900	
Spindle nose Camlock	DIN55029	D1-11		
Spindle inner taper	mm	150		
Spindle bore	mm	140		
Spindle nose	DIN55026	A2-15		
Max speed	rpm	1.000		
Spindle bore	mm	220		
Max. Turning torque	Nm	6.100		
Spindle nose	DIN55026	A2-20		
Max speed	rpm	500/700		
Spindle bore	mm	320		
Max. Turning torque	Nm	6.100		
Spindle nose	DIN55026	A2-20		
Max speed	rpm	-	500	-
Spindle bore	mm	-	360	-
Max. Turning torque	Nm	-	6.100	-
Spindle nose	DIN55026	A2-28		
Max speed	rpm	-	350	-
Spindle bore	mm	-	450	-
Max. Turning torque	Nm	-	6.100	-
SUPPORT				
Cross slide travel X-axis	mm	505	570	610
Rapid travel Z-axis	m/min	6		
Rapid travel X-axis	m/min	6		
Feed force longitudinal	kN	27/31		
Feed force transverse	kN	20		
Ball screw Z-axis Ball	mm	63		
screw X-axis	mm	40		
Manual Tool post Type Multifix	Size	D1		
TAILSTOCK				
Quill diameter	mm	125 (140/160 option)		
Quill taper	MT	6 (MTS for option with bearing system) 300		
Quill stroke	mm			
GENERAL				
Width of bed	mm	700		
Weight of machine				
2.000 mm	kg	10.100	10.500	10.900
3.000 mm	kg	11.000	11.400	11.800
4.000 mm	kg	11.900	12.300	12.500
5.000 mm	kg	12.800	13.200	13.600
6.000 mm	kg	13.700	14.100	15.200
16.000 mm	kg	22.700	23.100	23.500

* The data in the table refer to the basic version of the lathe. They may differ depending on the version of the machine and additional equipment. In particular, the tool system, special covers and doors, type of tailstock, handle, steady rests and other options.

PROFITTURN 1150/1350/1550 MN SERIES

The PROFITTURN MN lathe is designed for machining heavy components up to 1,550 mm in diameter. This series offers manufacturers heavy duty machining with the guarantee of durability, precision and stability.

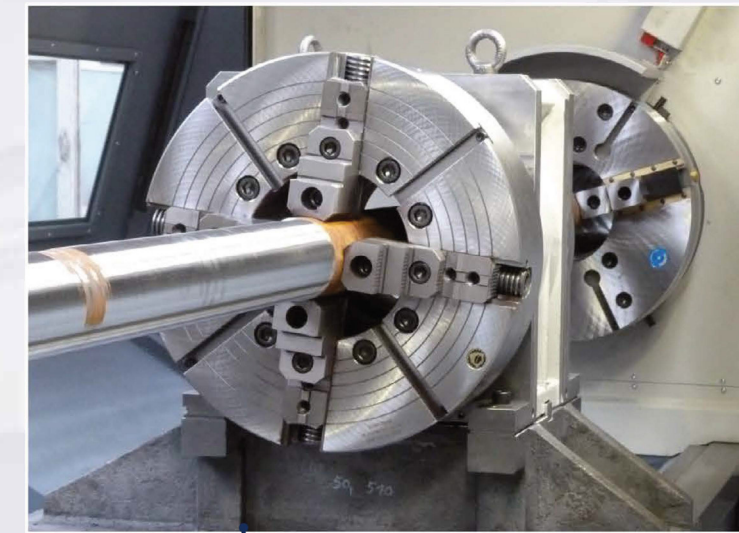
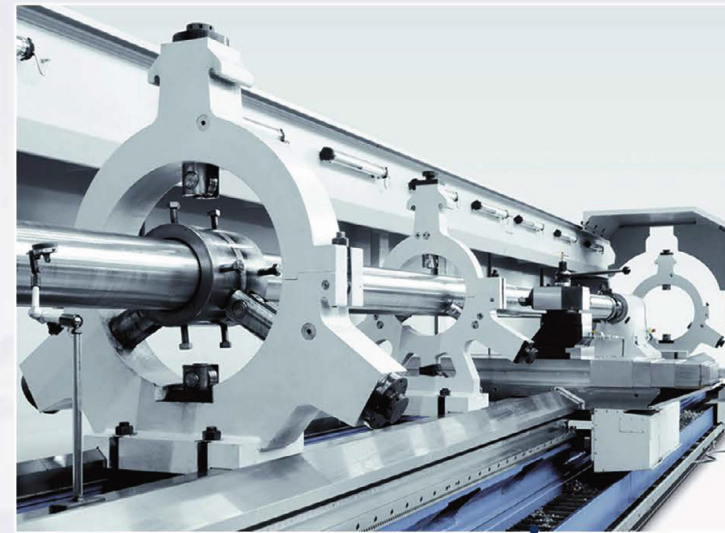

A wide range of rests is available to suit different machining applications, including: manual, hydraulic self-centering, follow rests, C-form, ring type and other.

CARRIAGE

A "Master-Slave" drive system is used on lathes with machining lengths longer than 4M, using an automated backlash reduction system and linear scales to achieve very high accuracy. The carriage is driven by two synchronized motors, a gearbox and a rack. Lathes which have shorter machining length are equipped with a precise ball screw.

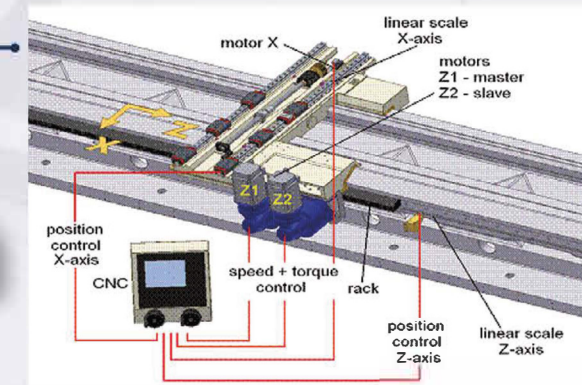

Advantages of "Master - Slave" solution: - automatic backlash elimination - high stiffness - maintenance free and no readjustment needed.

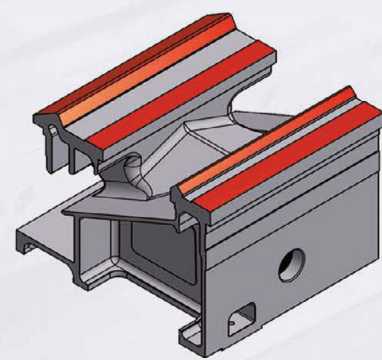
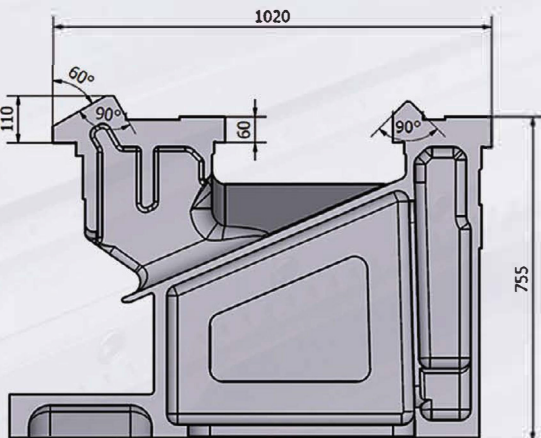

Special, mono-block type bed made of cast iron is a rigid structure which perfectly absorbs vibrations. Extra wide, deeply hardened and ground guide ways ensure precise machining of huge work pieces and excellent surface quality. All of the above guarantee long-life accurate operation of the lathe.

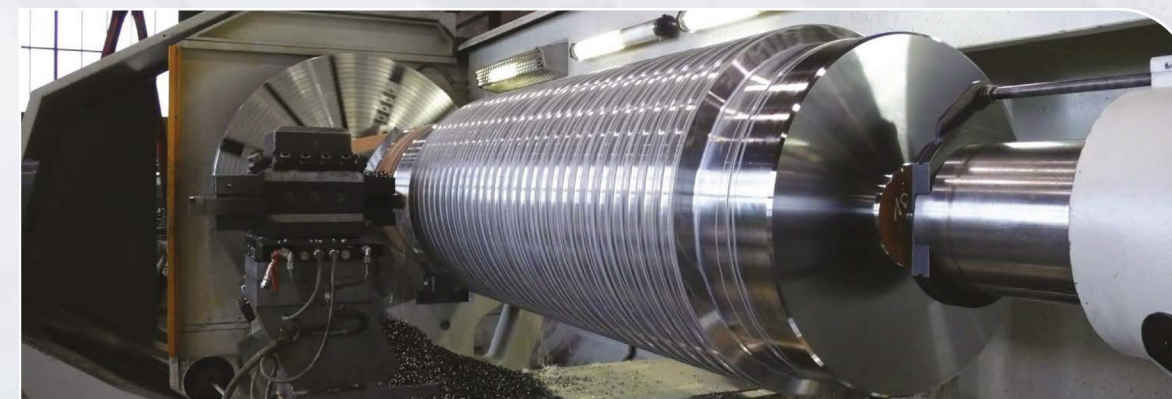

The body of the headstock, made of a single, ribbed, cast iron, was designed using the finite element method (FEM). This ensures the elimination of the weakest points of the structure and provides increased strength and rigidity of the structure. The headstock is subjected to a series of tests, both at the stage of making the casting, as well as in the subsequent stages of processing and final assembly.

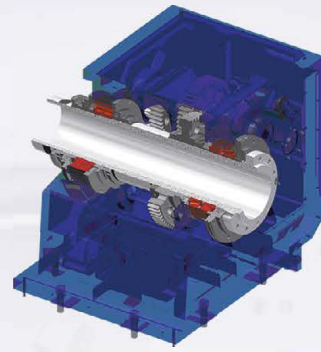
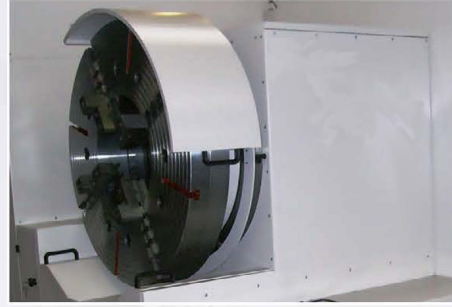
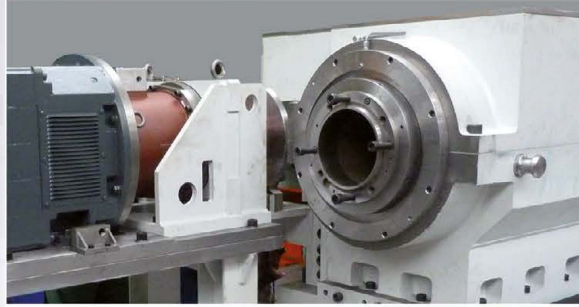

Special headstock with high powerful motor and additional planetary gearbox. With this solution it is possible to obtain a torque of up to 32 000 Nm

Dual nose spindle with a 450 mm diameter bore

A robust tailstock with an extended stroke allows the full working range (between tailstock housing and carriage) to be used. Due to this solution, heavy duty machining of any work piece held in the tailstock center is possible. The hydraulically operated quill with a diameter 220 mm (8,7") is hardened and ground. The Quill has a built-in bearing sleeve with taper socket MT6 for dead center. Quick coupling between the tailstock and cross slide makes positioning time short. Optionally, the tailstock can be equipped with an independent drive.

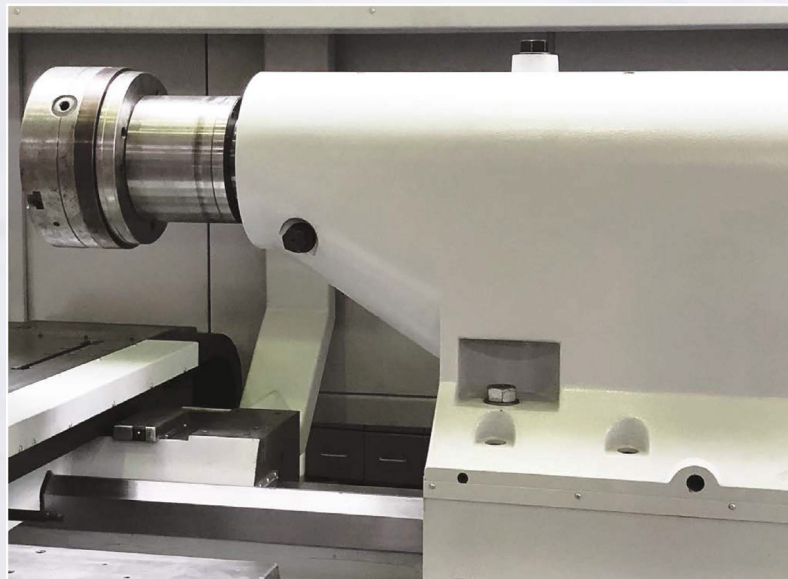
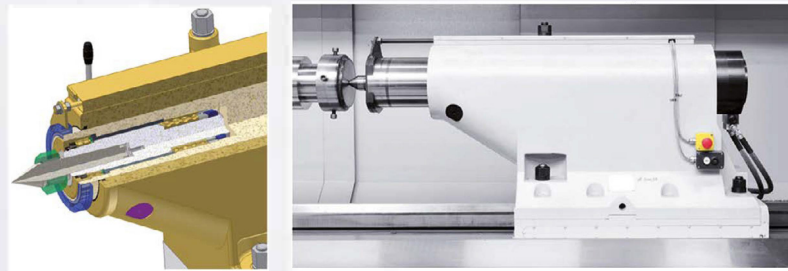
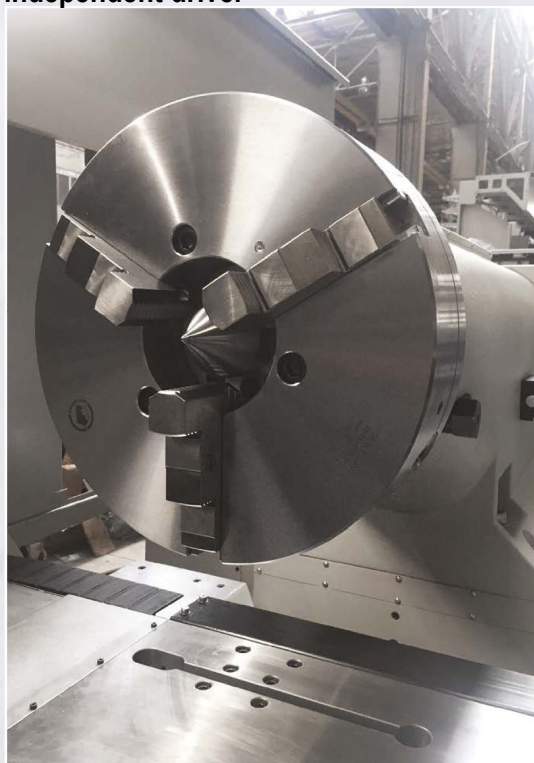

Tailstock quill with possibility mounting the chuck

STANDARD EQUIPMENT:

- Siemens Sinumerik One
- Third MPG portable handwheel
- Automatic programmable gearbox
- Tool post MULTIFIX D2 (without tool holders)
- Complete installation of coolant supply
- One movable front door (connected to cross slide)
- Sliding rear guard
- Hydraulic tailstock quill with built-in bearings system for dead center MT6
- Hydraulic aggregate
- Central lubrication system
- Front chip conveyor
- Direct linear scale for "Z" axis for machines with a turning length over 5,000 mm
- Absolute encoders of axial motors
- USB port
- Annual Siemens service contract

Zero Point Clamping Modules - system for quick change of different tooling solutions

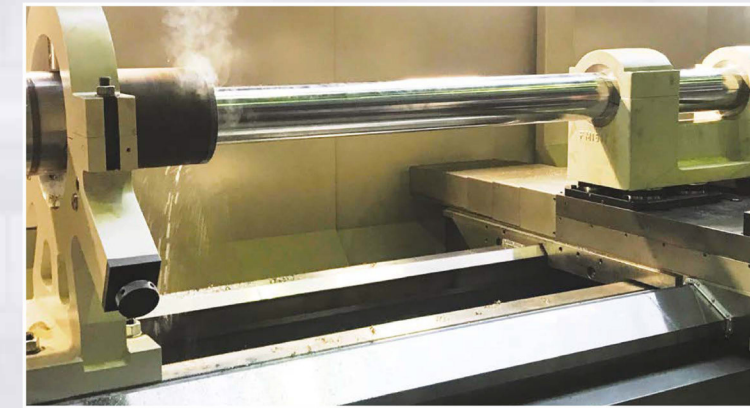

Special execution: turning diameter increased to 1.400 mm (55") above the carriage. Workpiece weight up to 20 000 kg (44 000 lbs). A heavy tailstock with 280 mm (11") quill diameter. Milling unit with automatic Y axis, mounted on the turret

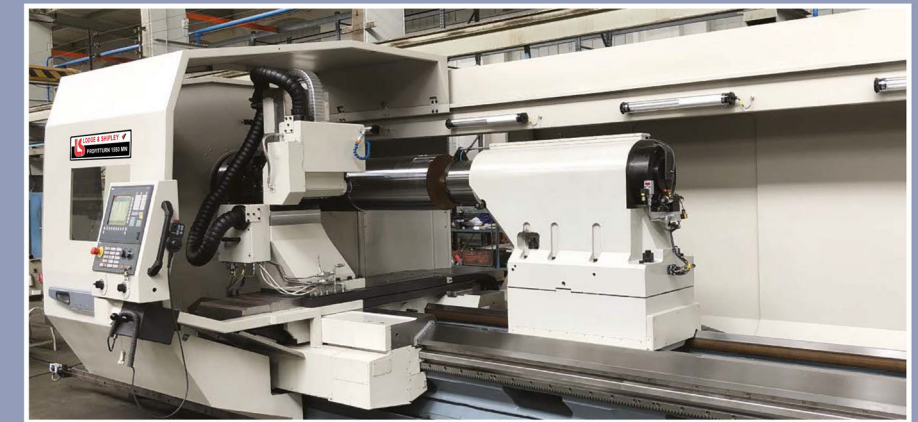

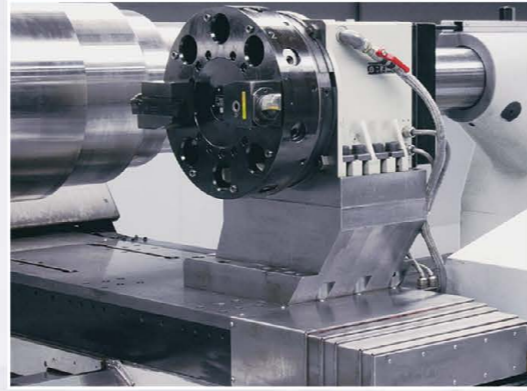

8-position tool turret

Milling units with automatic Y axis and double spindle, mounted on 4-position head turret

Disc turret for powered VDI60 tools

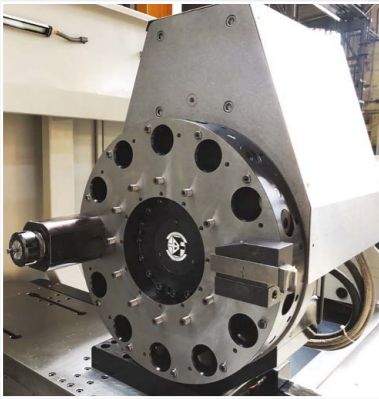

Standard Multifix D2 toolpost



Parat toolpost with optional Capto seat

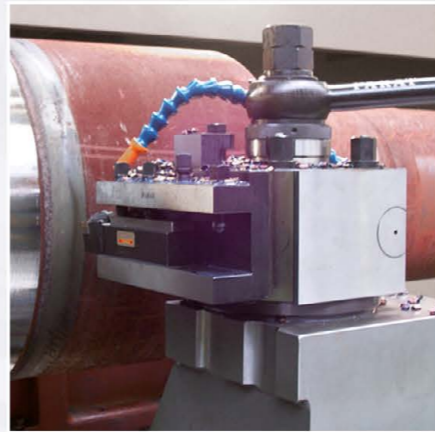

C axis with driven tools: - driven by main motor in combination with hydraulic brake and spindle encoder - full contouring C-axis driven directly by separate servo motor

Disc turret with integrated Y-axis



Double scrapers with compressed air for special guide ways security against grinding powder

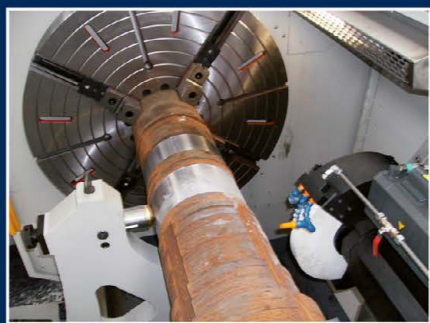

Grinding unit

TECHNICAL PARAMETERS: PROFITURN 1150/1350/1550 MN				
PROFITURN		1150 MN	1350 MN	1550 MN
CAPACITY				
Distance between centres	mm	2.000 – 4.000 – 6.000... – 16.000		
Swing over bed	mm	1150	1350	1550
Swing over saddle	mm	700	900	1.100/1.300
Max. weight between chuck and tailstock (without steadies)	kg	12.000 (20.000 option)		
Max. weight of workpiece in chuck only	kg	3.000		
HEADSTOCK				
Number of spindle ranges		2		
Spindle speed ranges (standard machine with 140 mm spindle bore)	rpm	I: 2-225, II: 180-1.000		
Main drive motor power (100%)	kW	41		
Max. Turning torque	Nm	8.250; (optional to 28.000)		
Standard spindle bore	mm	140		
Spindle nose	DIN55026	A2-15		
Spindle bore	mm	140		
Front bearings	mm	250		
Special execution of headstock:	mm	220	320	360
Spindle nose	DIN 55026	A2-15	A2-20	A2-20
Max. speed	rpm	1000	500/700	500
SUPPORT				
Cross slide travel X-axis	mm	650	750	775
Rapid travel Z-axis	m/min	8		
Rapid travel X-axis	m/min	10		
Feed force transverse	kN	25		
Feed force longitudinal	kN	55		
Ball screw Z-axis (2m, 4m and 5m between centers)	mm	80		
Z-axis drive on machines with turning lengths over 5 m	-	Gear rack with two motors in system "master &slave"		
Ball screw X-axis	mm	40		
Manual Tool post Type Multifix	Size	D2		
TAILSTOCK				
Quill diameter	mm	220 (280 option)		
Quill taper	MT	6		
Quill stroke	mm	300		
GENERAL				
Width of bed	mm	1.020		
Height of bed	mm	755		
Total length of machine				
2.000 mm	mm	5.200		
4.000 mm	mm	7.200		
6.000 mm	mm	9.200		
16.000 mm	mm	19.200		
Width of machine	mm	3.300		
Width of machine for transport	mm	2.350		
Height of machine	mm	2.550	2.550	2.750
Weight of machine				
2.000 mm	kg	16.500	17.300	18.100
4.000 mm	kg	19.000	19.800	20.600
6.000 mm	kg	21.500	22.300	23.100
16.000 mm	kg	34.000	34.800	35.600

* The data in the table refer to the basic version of the lathe. They may differ depending on the version of the machine and additional equipment. In particular, the tool system, special covers and doors, type of tailstock, handle, steady rests and other options.

NT 700 / NT 700 HV

The NT 700 slant bed CNC lathe has a cast heavy duty 70° inclined bed with 4 guide-ways. The swing over the bed is 700mm (optionally 840mm) and a length of up to 5100 mm between centers is available.

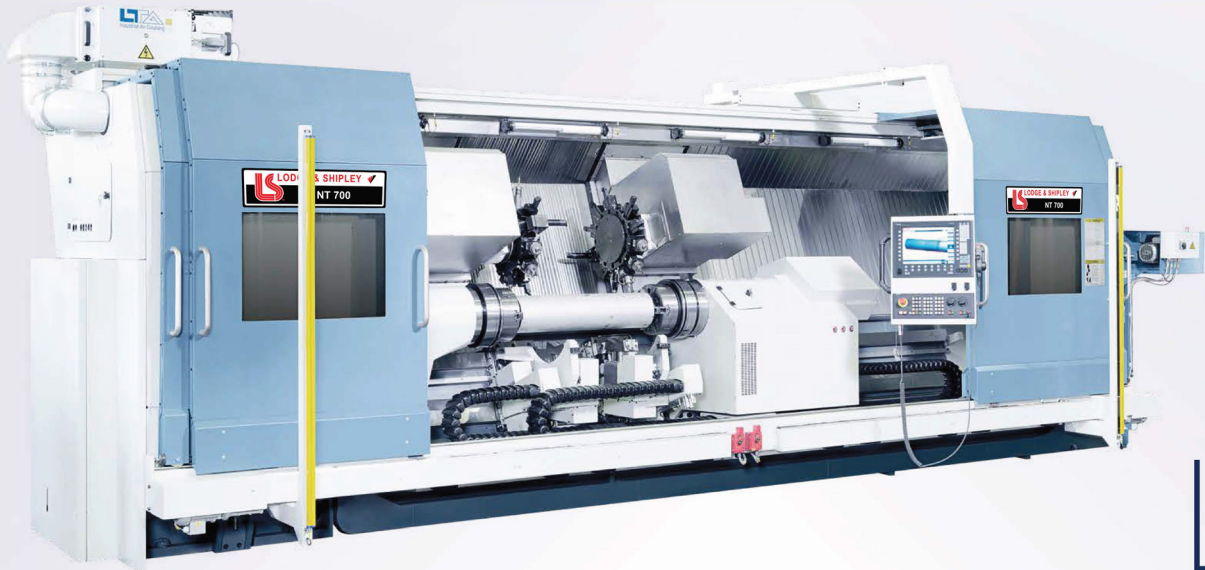

Two NT 700 lathes working with an integrated robot

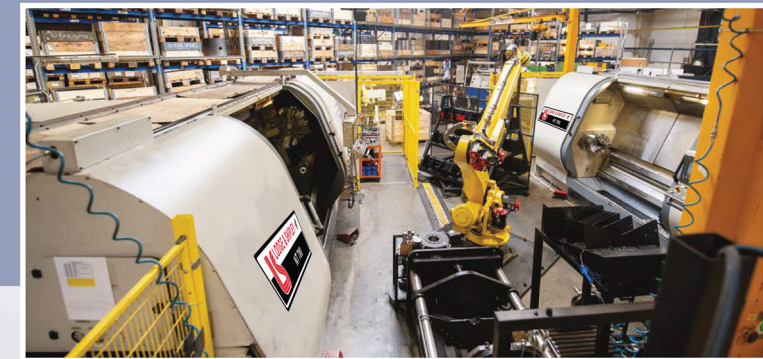

STANDARD EQUIPMENT:

- 12-position tool turret for static tools
- Complete coolant system
- Hydraulic tailstock quill with built-in bearing system
- Hydraulic aggregate
- Programmable positioning of tailstock with come-along system; hydraulic clamping to bed
- Chip conveyor
- Linear scale (direct measuring system) of the X-axis for higher repeatability and position accuracy
- Complete working area enclosure
- Absolute encoders

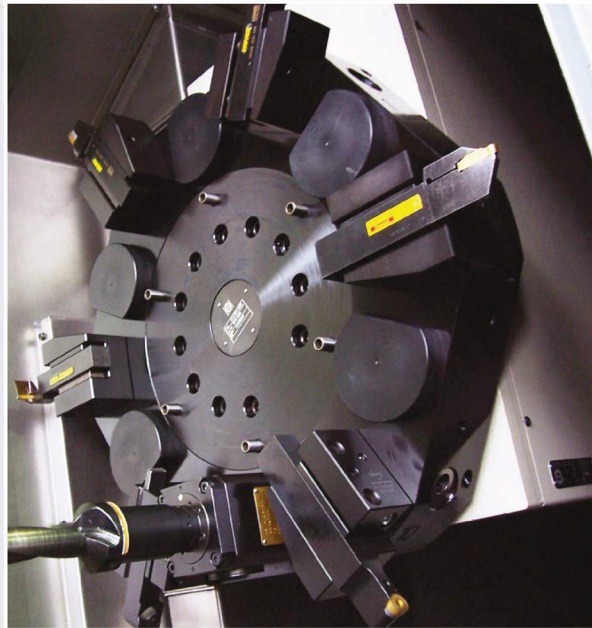

Standard 12 position tool turret



12 position turret radial Tool drive and integrated Y Axis

Oil mist collector

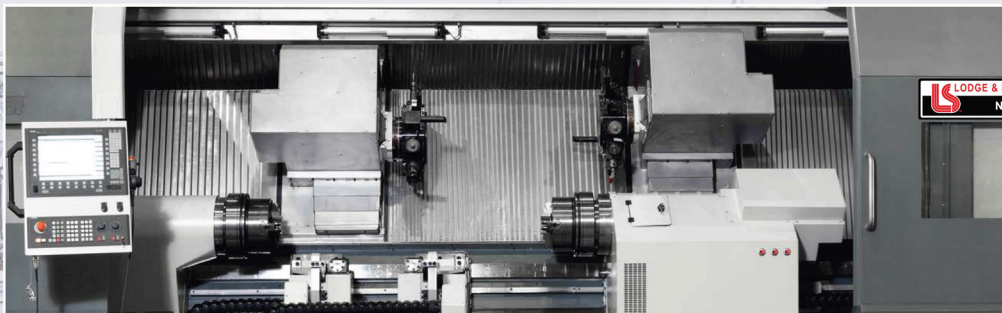

NT 700 with 840 mm (33") increased swing over bed and 2 independent carriages.



Work piece touch probe installed in turret socket



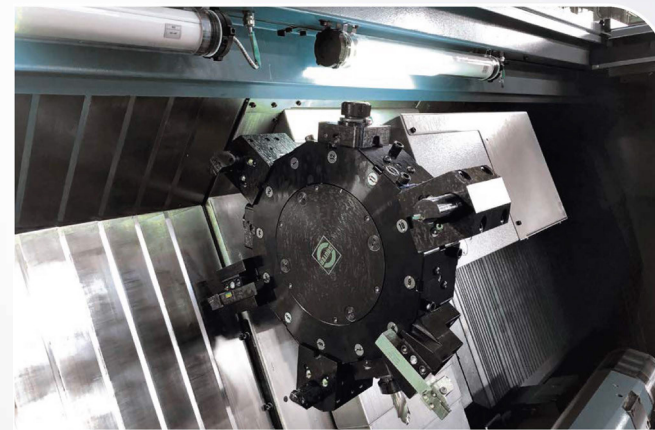

NT 700 - turning length 5.100mm (201"). Automatic door Independent tailstock NC drive and hydraulic steady rest. Turret with driven tools.

NT 700 x 1600 with 12 position disc turret with integrated Y-axis

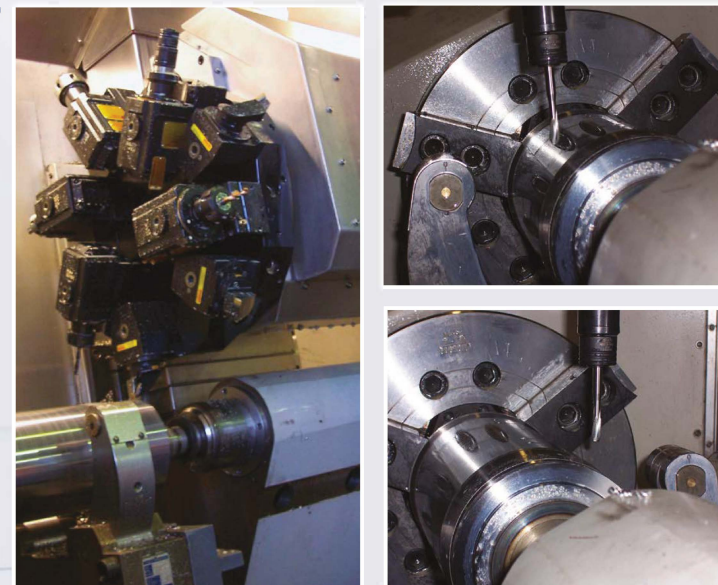
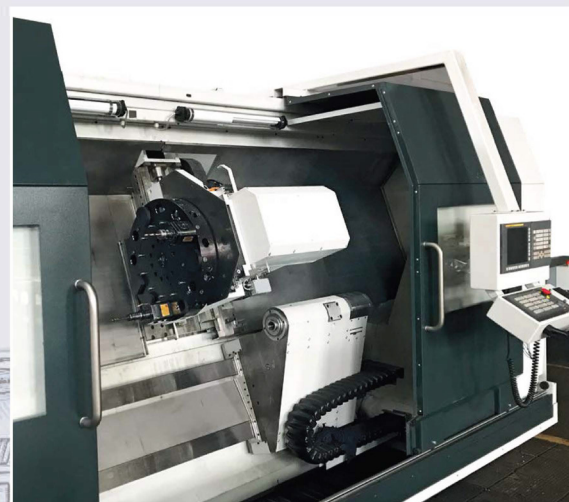

Disc turret with driven tools and Y axis

TECHNICAL PARAMETERS: NT 700

		NT 700	
CAPACITY			
Distance between centers	mm	1.100 - 1.600 - 2.100 - 3.100 - 4.100 - 5.100	
Swing over bed	mm	700 (840)	
Swing over saddle	mm	490 (630)	
Max. weight of workpiece between chuck and tail-stock (without steadies)	kg	2.500	
Max. weight in chuck only	kg	800	
HEADSTOCK			
Main drive motor power	kW	25	
Spindle bore	mm	105	
Spindle speed	rpm	2.500	
Max. turning torque with direct drive	Nm	850	
Max. turning torque with 2-range gearbox	Nm	3.400	
Spindle nose (DIN 55026 / 150702/1)	DIN 55026	A2-8	
Spindle inner taper	mm	115	
Spindle bore	mm	140	220
Spindle speed	rpm	2.500	2.000
Max. turning torque with direct drive	Nm	850	
Max. turning torque with 2-range gearbox	Nm	3.400	
Spindle nose (DIN 55026 / 150702/1)	DIN 55026	A2-11	A2-15
SADDLE			
Cross slide travel X-axis	mm	460	
Rapid travel Z-axis	m/min	20	
Rapid travel X-axis	m/min	20	
Feed force traverse	kN	21	
Feed force longitudinal	kN	21	
Ball screw Z-axis (1.100-3.100)	mm	50	
Ball screw Z-axis (4.100-5.100)	mm	65	
Ball screw X-axis	mm	40	
TOOLTURRET			
12-position tool turret for static tools		VDI 50	
TAILSTOCK			
Quill diameter	mm	120	
Quill taper	MT	MTS	
Quill stroke	mm	100	
SUB-SPINDLE			
Spindle bore	mm	90	
Top spindle speed	rpm	1800	
Spindle nose (DIN 55026 / 150702/1)	DIN 55026	A2-8	
Max. turning torque	Nm	950	
Max. motor power	kW	25	
GENERAL			
Width of machine	mm	2360	
Height of machine	mm	2540	
Weight of machine (approx.)			
NT 700 x 1100	kg	9600	
NT 700 x 1600	kg	11300	
NT 700 x 2100	kg	12600	
NT 700 x 3100	kg	14100	
NT 700 x 4100	kg	15500	
NT 700 x 5100	kg	16900	

Standard execution 10s:

Special execution 140/220:

* The data in the table refer to the basic version of the lathe. They may differ depending on the version of the machine and additional equipment. In particular, the tool system, special covers and doors, type of tailstock, handle, steady rests and other options.

NT 900

Modern machining center NT 900 is one of a range of CNC machine models supplied by Lodge & Shipley in North America. Due to the special design of the bed and the column, 900 mm turning diameter is not limited by the carriage slide. It ensures also optimum swarf removal, easy setting and operation, together with the best distribution of cutting forces. Constructed from high quality and high-tech components which offers manufacturers the highest level of machining with pure accuracy. The machine tool is available in three versions: standard NT 900, one with an integrated Y-axis (NT 900 Y) and another version, NT YH, with a higher column, enabling the integration of the milling head with the B axis, tool magazine and the extended Y-axis.



STANDARD EQUIPMENT:

- Siemens Sinumerik One
- 12-position turret for static tools
- Complete coolant system
- Hydraulic tailstock quill
- Hydraulic aggregate
- Programmable positioning of tailstock with come-along system; hydraulic clamping to bed
- Linear scale (direct measuring system) of the X-axis for higher repeatability and position accuracy
- Complete working area enclosure
- Chip conveyor
- Absolute encoders of axial motors

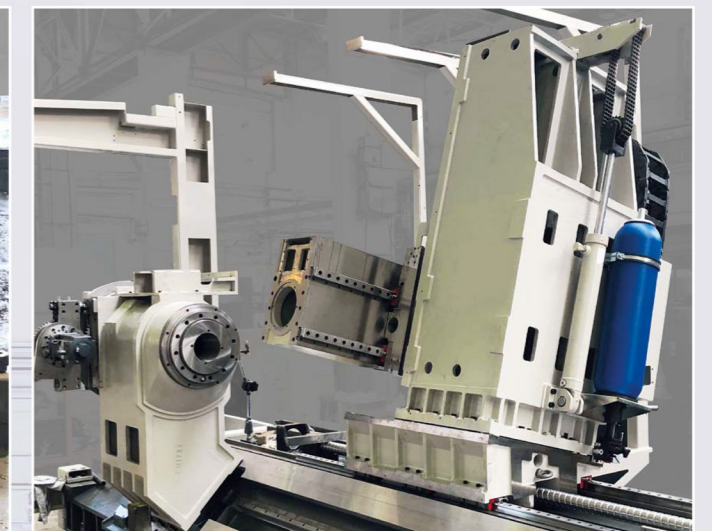
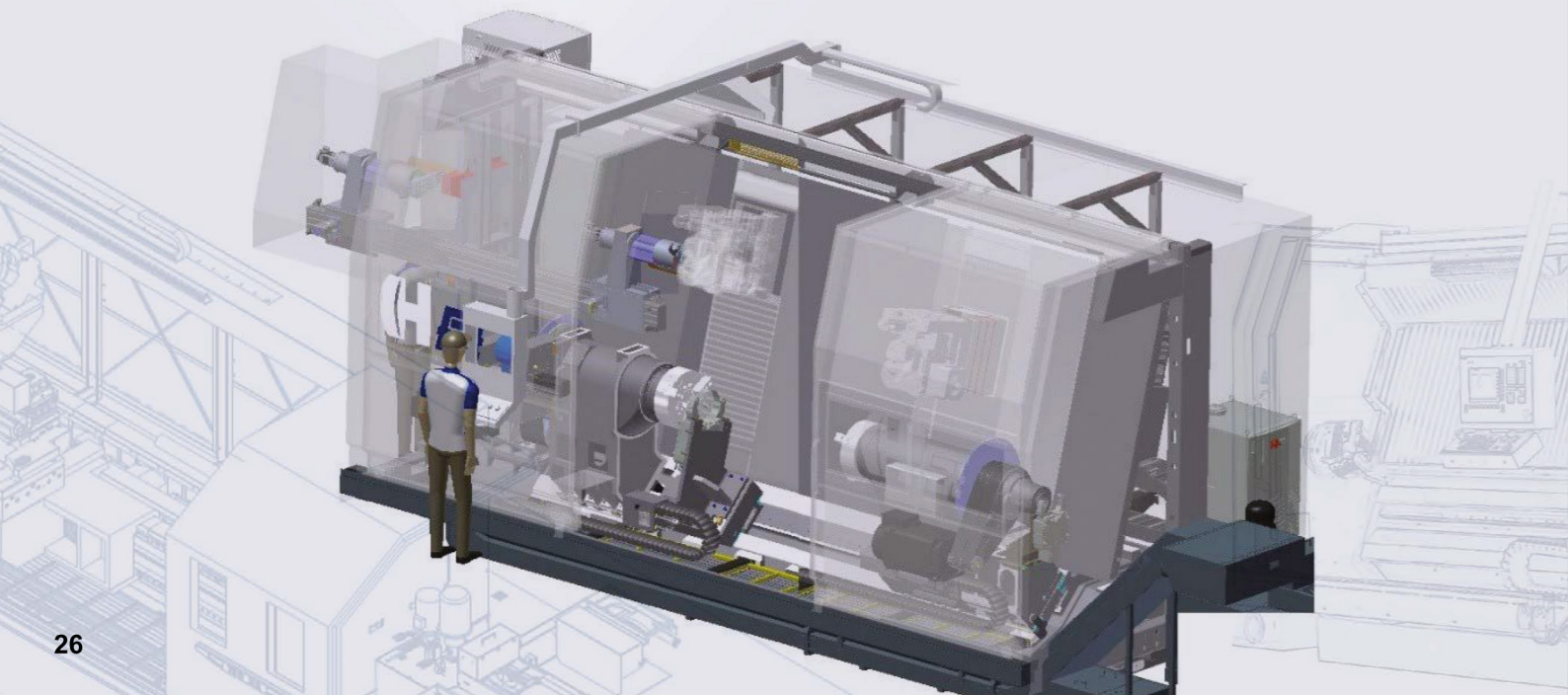

NT YH

OPTIONAL EQUIPMENT

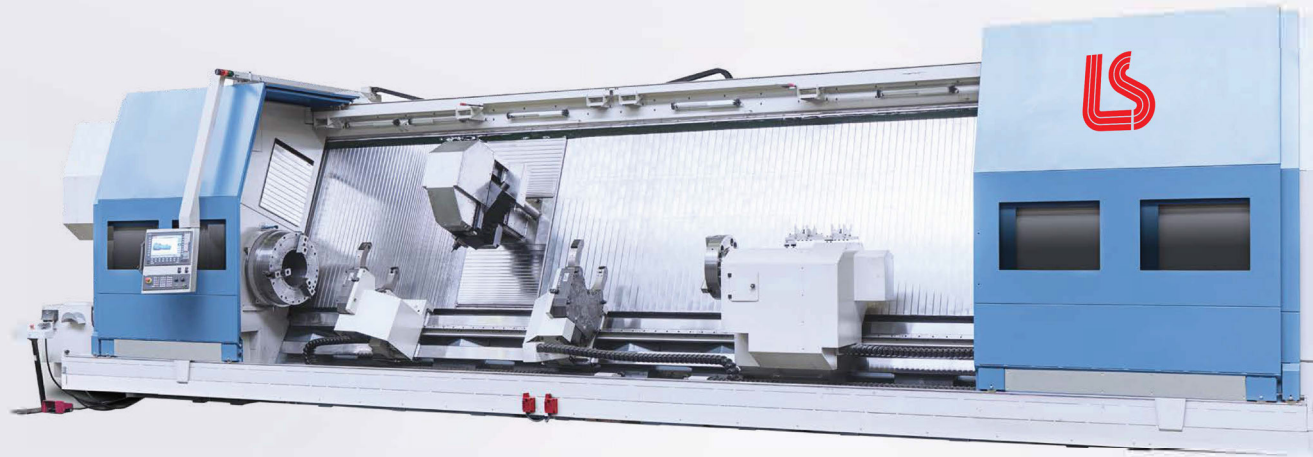

Hydraulic tailstock with automatic clamping to bed. Can be equipped with separate NC-drive

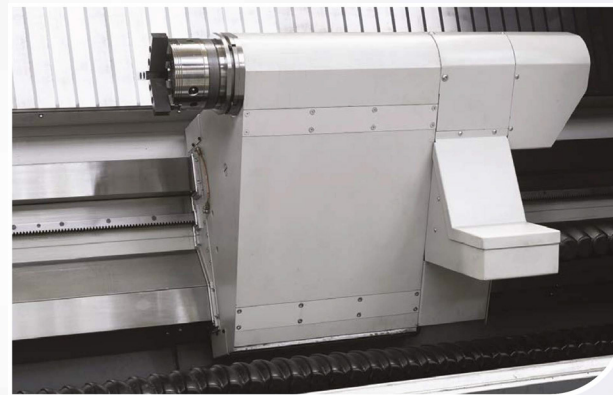

Whirling aggregate

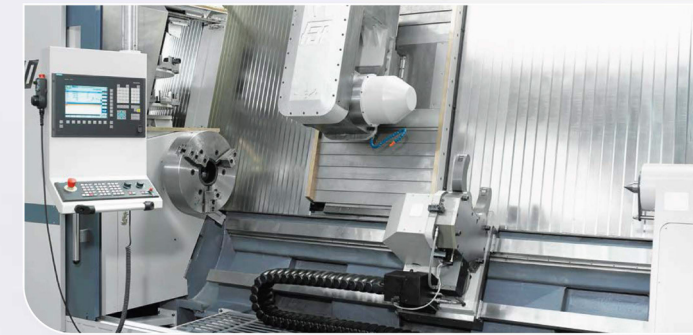

Hydraulic steady rest with independent NC drive



Pneumatic chuck with bore 360 mm (14.2")

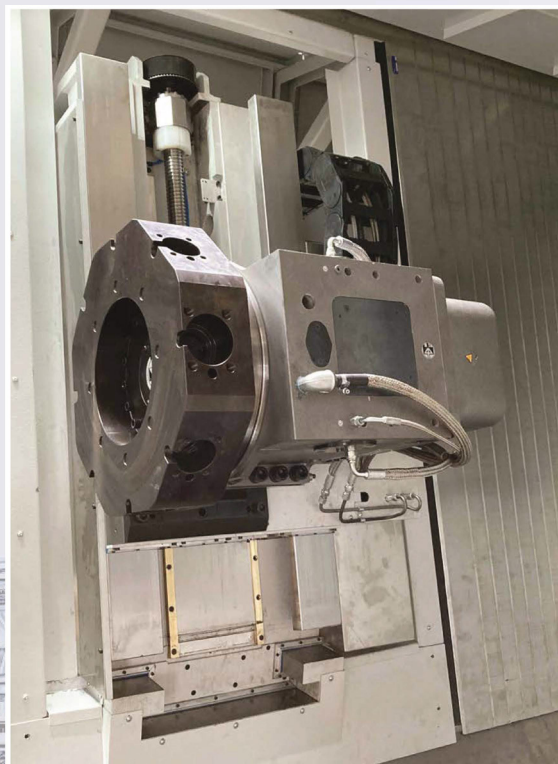

Baruffaldi turret with a special disc



OPTIONAL EQUIPMENT

VARIOUS TOOLING SYSTEMS



Turret with a special disc with axial and radial toolseats for driven and static tools



B-axis milling-turning head



Tool magazine

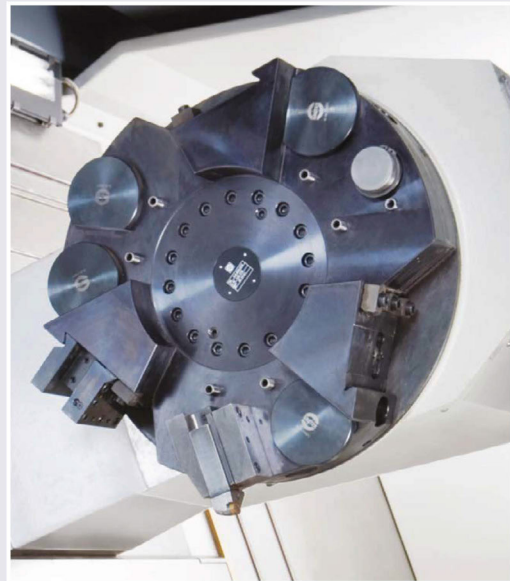

Special disc with slots for boring bars

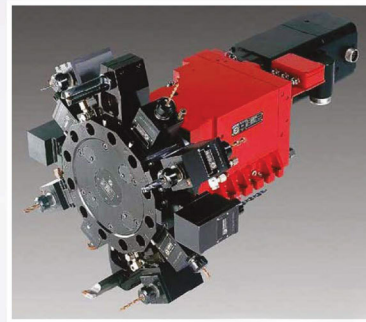

Turret with star type tool disc

Automatic measuring arm is hidden in the spindle box area behind automatic door. It comes into working area from the top of spindle for measuring operations. With this system it is possible to measure the tools when the work piece is installed on the machine

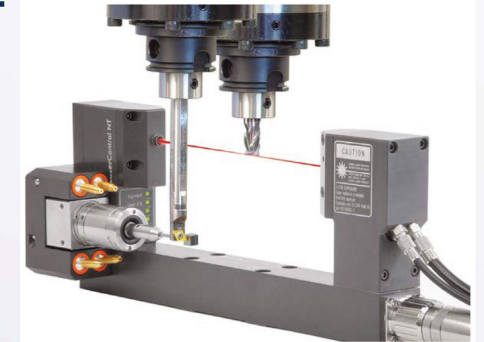

Combined tool setting system: non-contact measurement of rotating tools with laser and touch probe for static tools



Manual tool measuring arm



Boring bar holder mounted on the B-axis milling head. Parking position on the tailstock facilitates quick assembly.

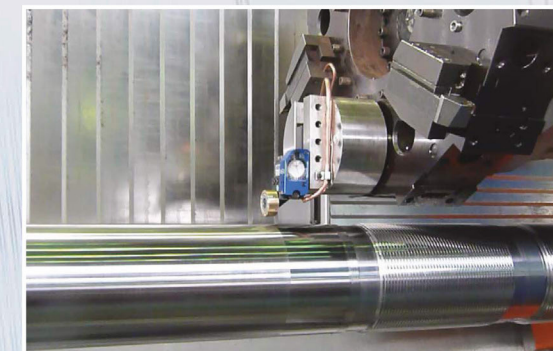

Burnishing with tool turret



Touch probe for workpiece measuring



Special boring bar attachment. The unit is designed for boring bar 120 mm (4.7") in diameter. The boring bar is mounted on swivel holder that lets the bar be put on parking position without disassembling.



▲ Hydraulic self-centering steady rest. Can be equipped with separate NC-drive.



▲ Sub-spindle

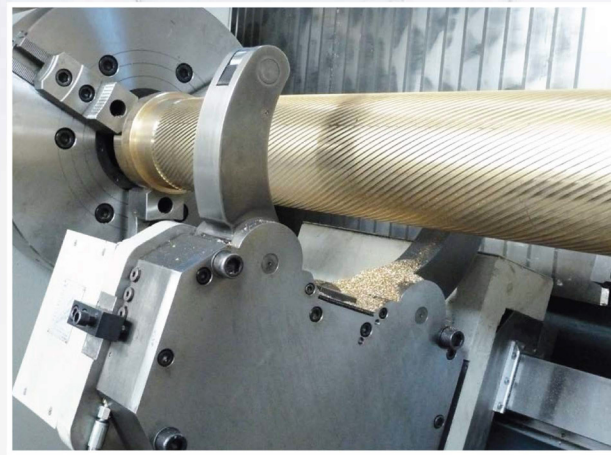

▲ Chuck and hydraulic steady rest

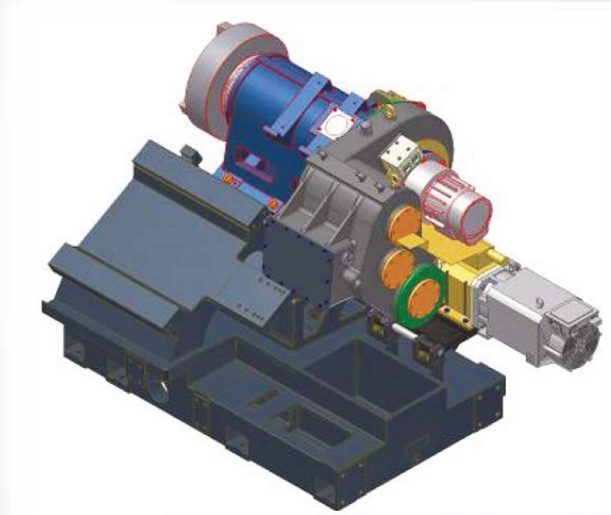

▲ Additional heavy-duty gearbox for increasing torque of spindle

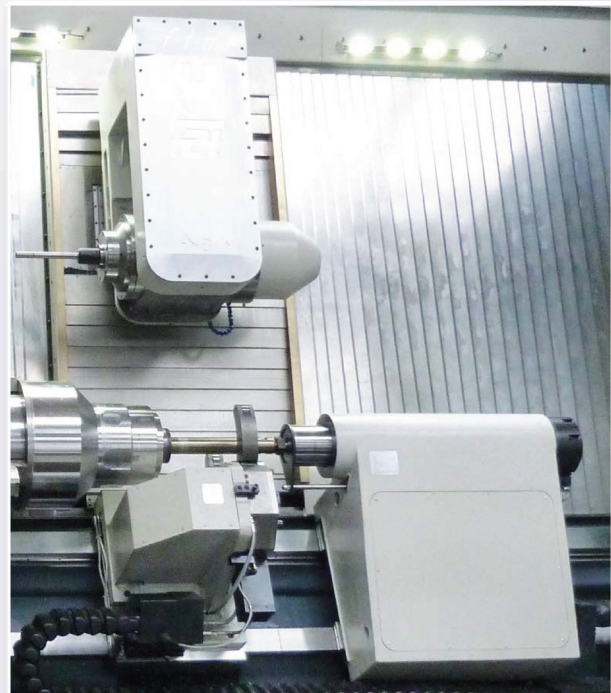

▲ Turning-milling head with B axis

TECHNICAL PARAMETERS: NT 900

		NT 900
CAPACITY		
Distance between centers	mm	1.900-2.900-3.900- 4.900-5.900-6.900-7.900
Swing over bed	mm	900
Swing over saddle	mm	900
Max. weight of workpiece between chuck and tail-stock (without steadies)	kg	4.500
Max. Weight in chuck only	kg	1.000
HEADSTOCK		
Number of spindle ranges		2
Main drive motor power (100%)	kW	41
Spindle bore	mm	140
Spindle speed	rpm	2.500
Max. turning torque with 2-range gearbox	Nm	3.500
Spindle nose (DIN 55026 / 150702/1) Spindle	DIN 55026	A2-15
Spindle bore	mm	220
Spindle speed	rpm	2.000
Max. turning torque with 2-range gearbox	Nm	3.500
Spindle nose (DIN 55026 / 150702/1)	DIN 55026	A2-15
COLUMN		
Cross slide travel X-axis	mm	650 / (990)
Z-axis travel	mm	1.350 / 2.350 / 3.350 ... /7.350
Y-axis long travel	mm	210 (±105)
Increased Y-axis travel	mm	
Rapid travel Z-axis	m/min	24
Rapid travel X-axis	m/min	15
Rapid travel Y-axis	m/min	15
Feed force transverse	kN	30
Feed force transverse in version FCTS YH	kN	40
Feed force longitudinal Feed	kN	30
Feed force longitudinal in version FCTS YH	kN	35
Ball screw Z-axis	mm	63
Ball screw X-axis	mm	50
Ball screw Y-axis	mm	50
Width of slide ways	mm	X=600, Y=600, Z=645
TOOLTURRET		
12-position tool turret for static tooling	DIN69880	VDI 50
TAILSTOCK		
Quill diameter	mm	160
Quill taper	MT	MT 6
Quill stroke	mm	150
SUBSPINDLE (option)		
Spindle bore	mm	105
Top spindle speed	rpm	1800
Spindle nose (DIN 55026 / 150702/1)	DIN 55026	A2-8
Max. turning torque	Nm	950
Weight of machine (approx.)		
FCTS 900 x 1.100	kg	22.000
FCTS 900 x 2.100	kg	24.000
FCTS 900 x 3.100	kg	26.000
FCTS 900 x 4.100	kg	28.000
FCTS 900 x 5.100	kg	30.000
FCTS 900 x 6.100	kg	32.000
FCTS 900 x 7.100	kg	34.000

Standard execution 140:
Standard execution 220:

* The data in the table refer to the basic version of the lathe. They may differ depending on the version of the machine and additional equipment. In particular, the tool system, special covers and doors, type of tailstock, handle, steady rests and other options.

SUPERTURN 3MN/4MN

Heavy 4-guideways lathe SUPERTURN 3MN is based on a single mono-bloc casting bed design incorporating 60Rc hardened and ground steel inserts, assembled using "Guide Easy FIX" technology. This enables easy guideway removal and refurbishment if ever necessary.

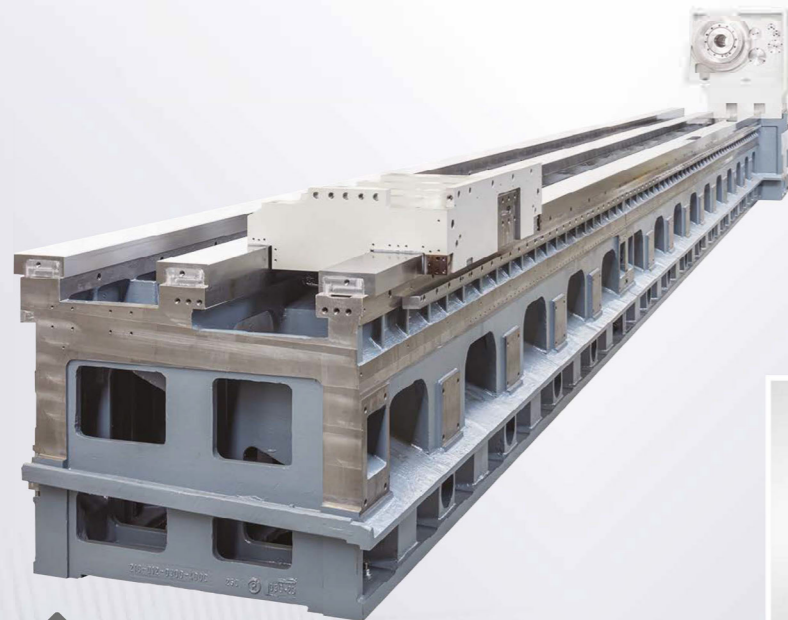
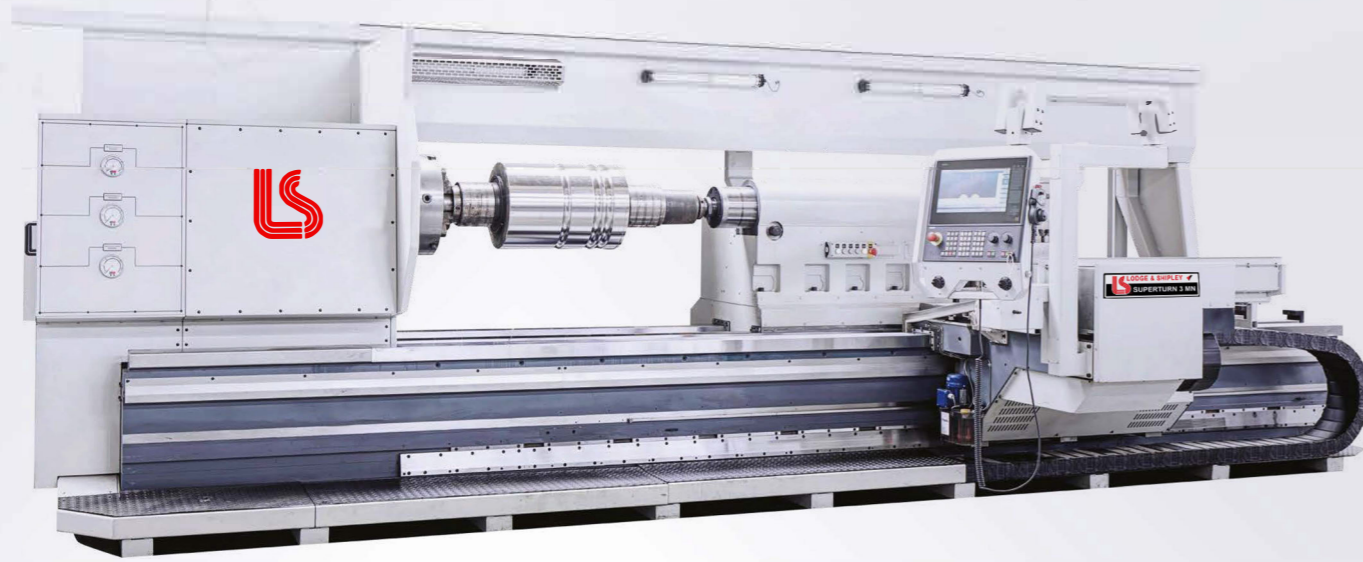

4-position head turret



Due to the compact structure of the bed, the machine takes up little space while maintaining stability.

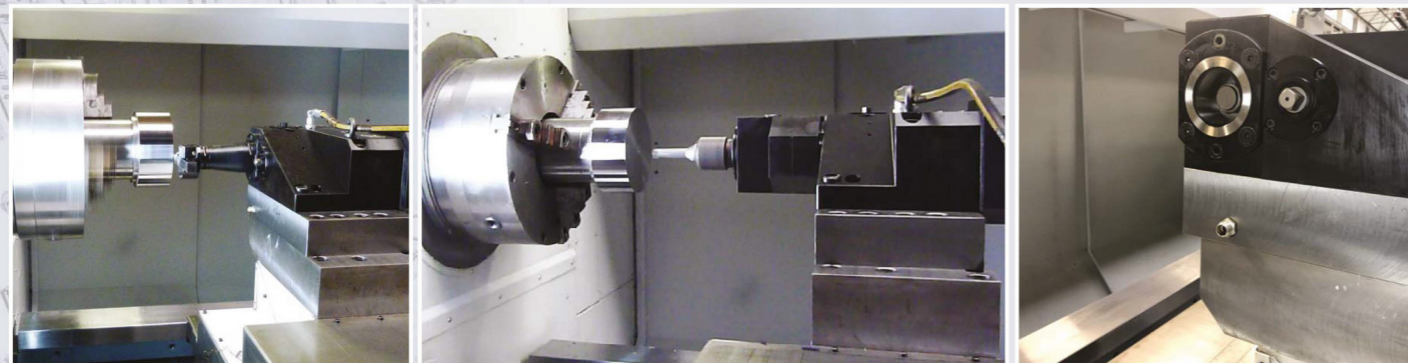

Tooling system WTO for turning, milling and drilling

The SUPERTURN 4MN is a CNC machine tool designed for heavy machining of large-size elements. A special bed „step-bed“ type ensures extremely stable processing using the full power of the machine.

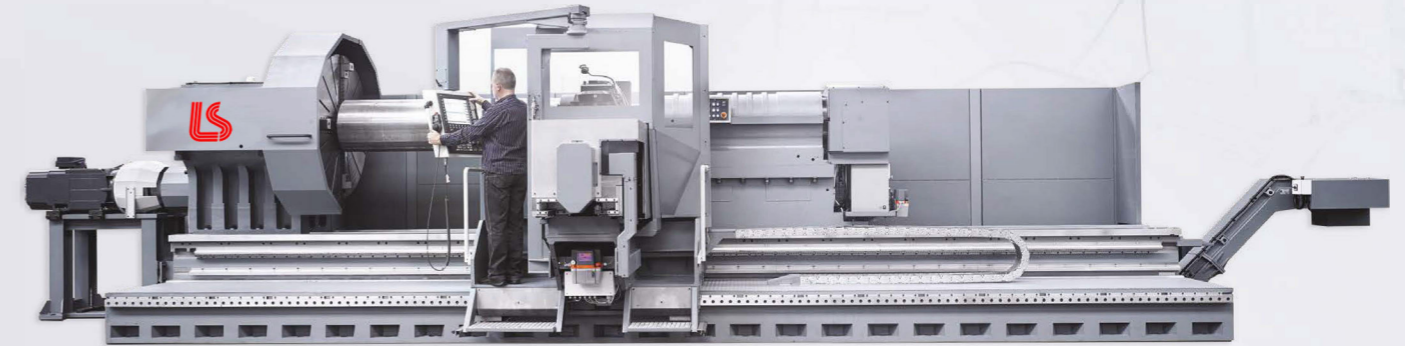

Tailstock with quill's diameter 400 mm (15,7") and stroke 300 mm (11,8"). Programmable positioning and automatic clamping to the bed.

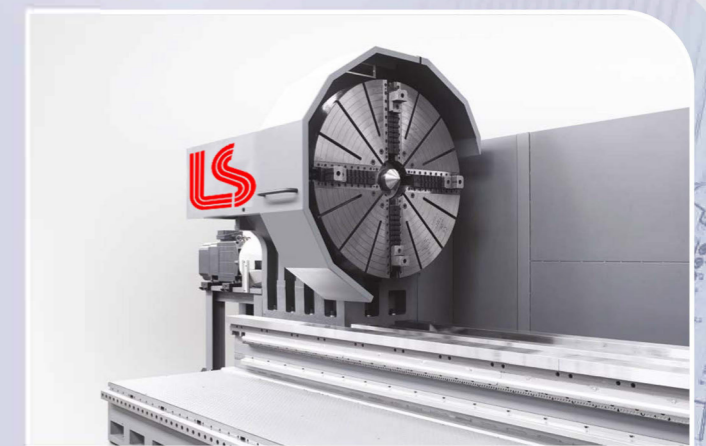

The heavy duty headstock is equipped with 185 mm (7,3") spindle bore. Thanks to the planetary gearbox, it is possible to obtain a turning torque of 100,000 Nm and more

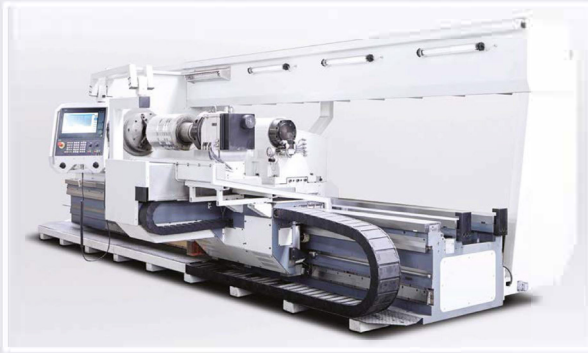

STANDARD EQUIPMENT:

- Siemens Sinumerik One
- Third handwheel (MPG)
- Automatic programmable gearbox
- Multifix D2
- Complete coolant system
- One movable front door (connected to cross slide)
- Full length rear guard
- Tailstock with hydraulic quill and separate drive; hydraulic clamping to the bed
- Chip conveyor
- Rotary control panel
- Absolute encoders of axial motors



▲ Ring steady rest

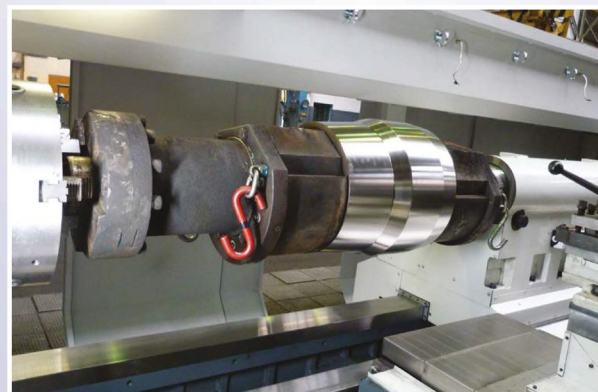

▲ Front door coupled with the carriage

▲ Type C



▲ TUR 4MN with full enclosure



▲ Cross slide without collision with the tailstock



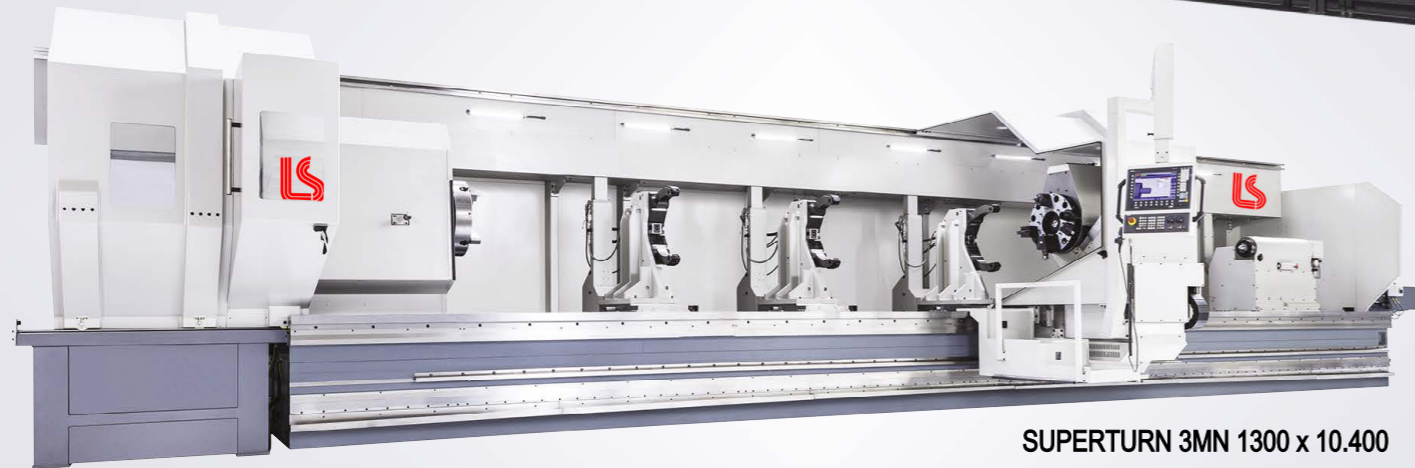
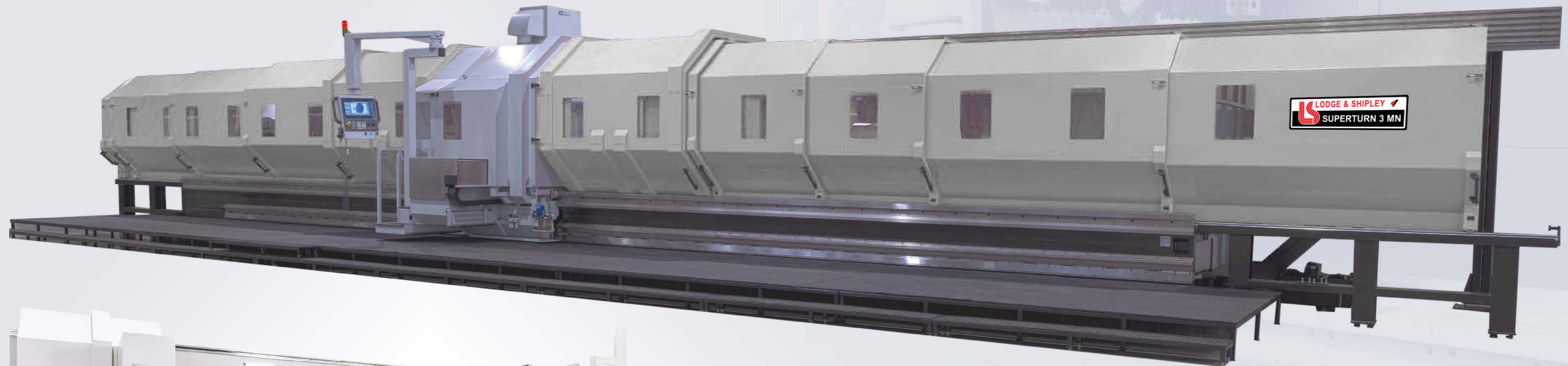

SUPERTURN 3MN 1300 x 10.400

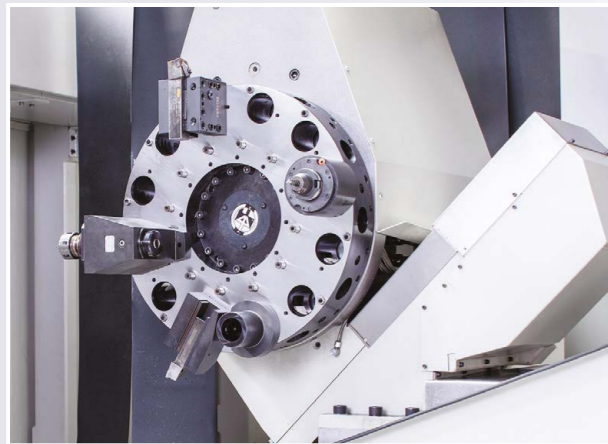

Disc turret on automatic Y-axis

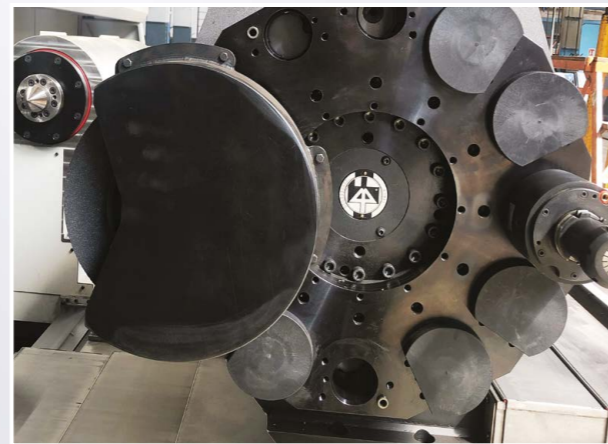

Tool disc with grinding attachment



Various types of steady rests



Boring bar holder with quick-change system

TECHNICAL PARAMETERS: SUPERTURN 3MN

		SUPERTURN 3 MN			
		Standard	Heavy		
CAPACITY					
Distance between centers (other lengths on special request)	mm	4.800 – 6.400 – 8.000 – 9.600 ... 16.000 and more			
Swing over bed	mm	1.300 - 1.500 1.600 - 1.900 (high bed)			
Swing over saddle	mm	1.000 - 1.200 1.300 - 1.600 (high bed)			
Max. weight between chuck and tailstock (without steadies)	kg	12.000	20.000		
Max. weight in chuck only	kg	3.000	3.000		
HEADSTOCK					
Number of spindle ranges		2			
Spindle speed ranges	rpm	I: 2-225, II: 180-1.000	I: 2-115 II: 100-700	I: 2-80 II: 60-350	
Main drive motor power (100%)	kW	41	60	71	
Max. Turning torque	Nm	8.200	28.000	42.500	
Normal execution:					
Spindle bore diameter:	mm	140	260	185	
Spindle nose	DIN55026	A2-15	A2-15	A2-20	
Special executions:					
Spindle bore diameter:	mm	220	320	360	450
Spindle nose	DIN55026	A2-15	A2-20	A2-20	A2-28
Max speed	rpm	1.000	500	450	350
SADDLE					
Rapid travel Z-axis	m/min	6			
Rapid travel X-axis	m/min	6			
Feed force longitudinal	kN	47			
Feed force transverse	kN	40			
TAILSTOCK					
Quill diameter	mm	220	280		
Quill stroke	mm	300	300 (optional 400)		

* The data in the table refer to the basic version of the lathe. They may differ depending on the version of the machine and additional equipment. In particular, the tool system, special covers and doors, type of tailstock, handle, steady rests and other options.

PREDATOR 550

The PREDATOR 550 is the smallest in the range of highly flexible turning and milling machines from Lodge & Shipley. It is based on a slant bed design which ensures optimum swarf removal, easy setting and operation, together with the best distribution of cutting forces.

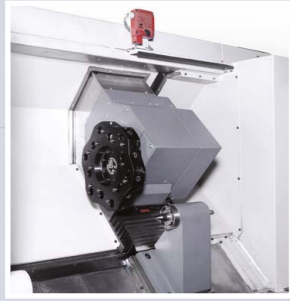

Standard 12 position turret with static tools VDI 30 seats

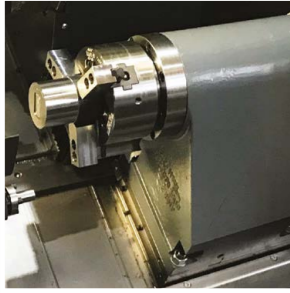

Sub-spindle



Hydraulic tailstock stroke 15 mm (0.6")



Automatic part catcher



PREDATOR 550 with turret "star" type, subspindle

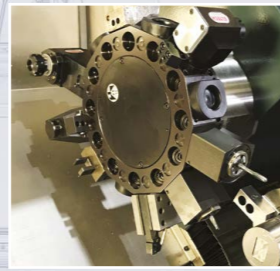

TECHNICAL PARAMETERS: PREDATOR 550

		PREDATOR 550
CAPACITY		
Distance between centres	mm	600 – 1.000
Swing over bed	mm	550
HEADSTOCK		
Top spindle speed	rpm	5.000
Main drive motor power	kW	20
Max. turning torque	Nm	190
S. bore without hydraulic cylinder and chuck		80 (105 - option)
SADDLE		
Cross slide travel X-axis	mm	210
Rapid travel Z-axis	m/min	30
Rapid travel X-axis	m/min	30
TOOL TURRET		
12-position turret for static tools	VDI	30
TAILSTOCK		
Quill taper	size	MT4
Travel method		auto positioning
Quill diameter	mm	55
Hydr. stroke of tailstock	mm	15
Thrust	N	4.400

* The data in the table refer to the basic version of the lathe. They may differ depending on the version of the machine and additional equipment. In particular, the tool system, special covers and doors, type of tailstock, handle, steady rests and other options.



monarchlathe.com

LODGE & SHIPLEY

POWER... PRECISION... PERFORMANCE!

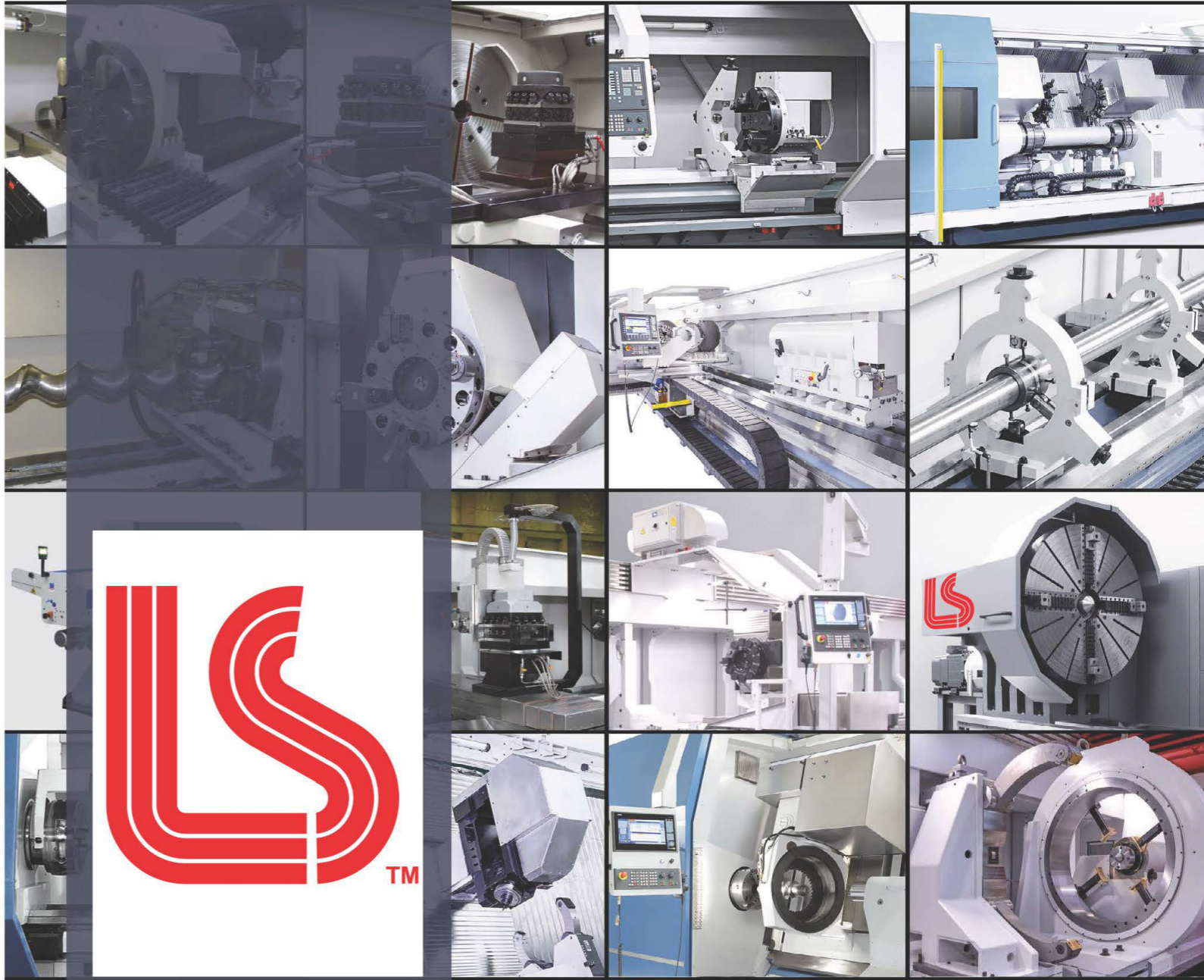

for impressive
performances

FORM MORE INFORMATION CONTACT:

MONARCHLATHES, L.P.
615 OAK AVENUE
P.O. BOX 4609
SIDNEY, OHIO
45365-4609
PHONE: 937-492-4111 EMAIL: sales@monarchlathe.com
WEBSITE: www.monarchlathe.com

